

DIVERSIFIED HEALTH OCCUPATIONS

Seventh Edition

**Louise Simmers, MEd, RN
Karen Simmers-Nartker, BSN, RN
Sharon Simmers-Kobelak, BBA**



Australia • Brazil • Japan • Korea • Mexico • Singapore • Spain • United Kingdom • United States

Diversified Health Occupations, Seventh Edition

Louise Simmers
Karen Simmers-Nartker
Sharon Simmers-Kobelak

Vice President, Career and Professional Editorial: Dave Garza

Director of Learning Solutions: Matthew Kane

Managing Editor: Marah Bellegarde

Acquisitions Editor: Matthew Seeley

Senior Product Manager: Juliet Steiner

Editorial Assistant: Megan Tarquinio

Vice President, Marketing, Career and Professional: Jennifer McAvey

Marketing Manager: Michele McTighe

Technology Project Manager: Ben Knapp

Production Director: Carolyn Miller

Senior Art Director: Jack Pendleton

Content Project Manager: Anne Sherman

© 2009 Delmar, Cengage Learning

ALL RIGHTS RESERVED. No part of this work covered by the copyright herein may be reproduced, transmitted, stored, or used in any form or by any means, graphic, electronic, or mechanical, including but not limited to photocopying, recording, scanning, digitizing, taping, Web distribution, information networks, or information storage and retrieval systems, except as permitted under Section 107 or 108 of the 1976 United States Copyright Act, without the prior written permission of the publisher.

For product information and technology assistance, contact us at
Cengage Learning Academic Resource Center, 1-800-423-0563

For permission to use material from this text or product, submit all requests
online at **www.cengage.com/permissions**

Further permissions questions can be emailed to
permissionrequest@cengage.com

ExamView® and ExamView Pro® are registered trademarks of FSCreations, Inc. Windows is a registered trademark of the Microsoft Corporation used herein under license. Macintosh and Power Macintosh are registered trademarks of Apple Computer, Inc. Used herein under license.

© 2009 Cengage Learning. All Rights Reserved. Cengage Learning WebTutor™ is a trademark of Cengage Learning.

Library of Congress Control Number: 2007941692

ISBN-13: 978-1-4180-3021-6

ISBN-10: 1-4180-3021-X

Delmar Cengage Learning

5 Maxwell Drive
Clifton Park, NY 12065-2919
USA

Cengage Learning products are represented in Canada by Nelson Education, Ltd.

For your lifelong learning solutions, visit **delmar.cengage.com**

Visit our corporate website at **www.cengage.com**

Notice to the Reader

Publisher does not warrant or guarantee any of the products described herein or perform any independent analysis in connection with any of the product information contained herein. Publisher does not assume, and expressly disclaims, any obligation to obtain and include information other than that provided to it by the manufacturer. The reader is expressly warned to consider and adopt all safety precautions that might be indicated by the activities described herein and to avoid all potential hazards. By following the instructions contained herein, the reader willingly assumes all risks in connection with such instructions. The publisher makes no representations or warranties of any kind, including but not limited to, the warranties of fitness for particular purpose or merchantability, nor are any such representations implied with respect to the material set forth herein, and the publisher takes no responsibility with respect to such material. The publisher shall not be liable for any special, consequential, or exemplary damages resulting, in whole or part, from the readers' use of, or reliance upon, this material.

CHAPTER 14

Infection Control

Chapter Objectives

After completing this chapter, you should be able to:

- ◆ Identify five classes of microorganisms by describing the characteristics of each class
- ◆ List the 6 components of the chain of infection
- ◆ Differentiate between antisepsis, disinfection, and sterilization
- ◆ Define bioterrorism and identify at least four ways to prepare for a bioterrorism attack
- ◆ Wash hands following aseptic technique
- ◆ Observe standard precautions while working in the laboratory or clinical area
- ◆ Wash, wrap, and autoclave instruments, linen, and equipment
- ◆ Operate an autoclave with accuracy and safety
- ◆ Follow basic principles on chemical disinfection
- ◆ Clean instruments with an ultrasonic unit
- ◆ Open sterile packages with no contamination
- ◆ Don sterile gloves with no contamination
- ◆ Prepare a sterile dressing tray with no contamination
- ◆ Change a sterile dressing with no contamination
- ◆ Don and remove a transmission-based isolation mask, gloves, and gown
- ◆ Relate specific basic tasks to the care of a patient in a transmission-based isolation unit
- ◆ Define, pronounce, and spell all key terms

Observe Standard Precautions



Instructor's Check—Call Instructor at This Point



Safety—Proceed with Caution



OBRA Requirement—Based on Federal Law



Math Skill



Legal Responsibility



Science Skill



Career Information



Communications Skill



Technology



KEY TERMS

acquired immune deficiency syndrome (AIDS)	contaminated	pathogens (<i>path'-oh-jenz'</i>)
aerobic	disinfection	personal protective equipment (PPE)
airborne precautions	droplet precautions	portal of entry
anaerobic	endogenous	portal of exit
antisepsis (<i>ant''-ih-sep'-sis</i>)	epidemic	protective (reverse) isolation
asepsis (<i>a-sep'-sis</i>)	exogenous	protozoa (<i>pro-toe-zo'-ah</i>)
autoclave	fomites	reservoir
bacteria	fungi (<i>fun'-guy</i>)	rickettsiae (<i>rik-et'-z-ah</i>)
bioterrorism	helminths	standard precautions
causative agent	hepatitis B	sterile
cavitation (<i>kav''-ih-tay'-shun</i>)	hepatitis C	sterile field
chain of infection	microorganism (<i>my-crow-or'-gan-izm</i>)	sterilization
chemical disinfection	mode of transmission	susceptible host
clean	nonpathogens	transmission-based isolation precautions
communicable disease	nosocomial	ultrasonic
contact precautions	opportunistic	viruses
	pandemic	

14:1 INFORMATION



Understanding the Principles of Infection Control



Understanding the basic principles of infection control is essential for any health care worker in any field of health care. The principles described in this unit provide a basic knowledge of how disease is transmitted and the main ways to prevent disease transmission.

A **microorganism**, or microbe, is a small, living organism that is not visible to the naked eye. It must be viewed under a microscope. Microorganisms are found everywhere in the environment, including on and in the human body. Many microorganisms are part of the normal flora (plant life adapted for living in a specific environment) of the body and are beneficial in maintaining certain body processes. These are called **nonpathogens**. Other microorganisms cause infection and disease and are called **pathogens**, or germs. At times, a microorganism that is beneficial in one body system can become pathogenic when it is present in another body system.

For example, a bacterium called *Escherichia coli* (*E. coli*) is part of the natural flora of the large intestine. If *E. coli* enters the urinary system, however, it causes an infection.

To grow and reproduce, microorganisms need certain things. Most microorganisms prefer a warm environment, and body temperature is ideal. Darkness is also preferred by most microorganisms, and many are killed quickly by sunlight. In addition, a source of food and moisture is needed. Some microorganisms, called **aerobic** organisms, require oxygen to live. Others, called **anaerobic** organisms, live and reproduce in the absence of oxygen. The human body is the ideal supplier of all the requirements of microorganisms.

CLASSES OF MICROORGANISMS

There are many different classes of microorganisms. In each class, some of the microorganisms are pathogenic to humans. The main classes include:

◆ **Bacteria:** These are simple, one-celled organisms that multiply rapidly. They are classified by shape and arrangement. *Cocci* are round or spherical in shape (figure 14-1). If cocci occur in pairs, they are diplococci. Diplococci bacteria cause diseases such as gonorrhea, meningitis, and pneumonia. If cocci occur in chains, they are streptococci. A common streptococcus causes a severe sore throat (strep throat) and rheumatic fever. If cocci occur in clusters or groups, they are staphylococci. These are the most common pyogenic (pus-producing) microorganisms. Staphylococci cause infections such as boils, urinary tract infections, wound infections, and toxic shock. Rod-shaped bacteria are called *bacilli* (figure 14-2). They can occur singly, in pairs, or in chains. Many bacilli contain flagella, which are thread-like projections that are similar to tails and allow the organisms to move. Bacilli also have the ability to form spores, or thick-walled capsules, when conditions for growth are poor. In the spore form, bacilli are extremely difficult to kill. Diseases caused by different types of bacilli include tuberculosis, tetanus, pertussis, (whooping cough), botulism, diphtheria, and typhoid. Bacteria that are spiral or corkscrew in shape are called *spirilla* (figure 14-3). These include the comma-shaped vibrio and the corkscrew-shaped spirochete. Diseases caused by spirilla include syphilis and cholera. Antibiotics are used to kill bacteria. However, some strains of bacteria have become antibiotic-

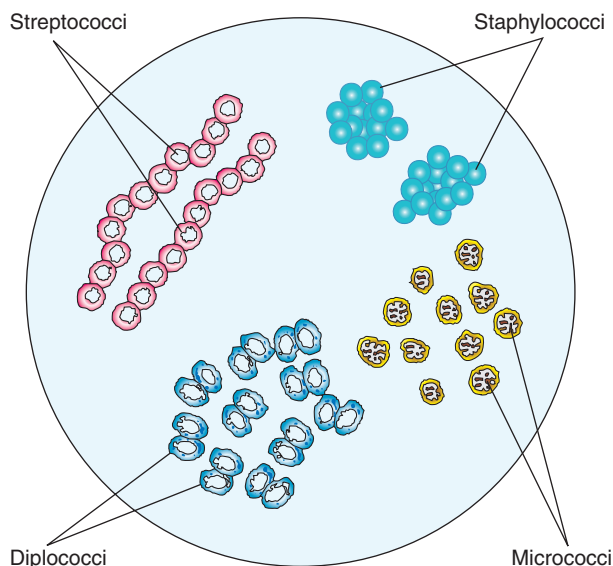

FIGURE 14-1 Kinds of cocci bacteria.

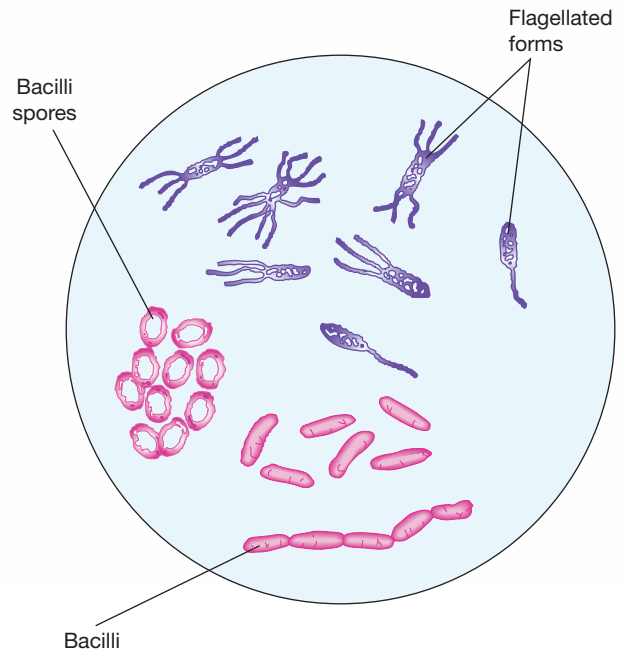

FIGURE 14-2 Bacilli bacteria.

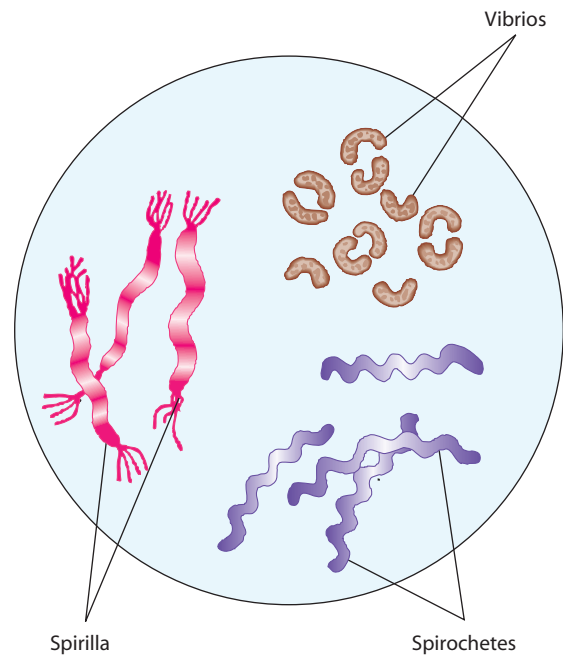

FIGURE 14-3 Spirilla bacteria.

resistant, which means that the antibiotic is no longer effective against the bacteria. Methicillin-resistant staphylococcus is an example. It causes a severe Staph infection that is difficult to treat because it is resistant to many different antibiotics.

◆ **Protozoa:** These are one-celled animal-like organisms often found in decayed materials, animal or bird feces, insect bites, and con-

taminated water (figure 14-4). Many contain flagella, which allow them to move freely. Some protozoa are pathogenic and cause diseases such as malaria, amebic dysentery (intestinal infection), trichomonas, and African sleeping sickness.

- ◆ **Fungi:** These are simple, plantlike organisms that live on dead organic matter. Yeasts and molds are two common forms that can be pathogenic. They cause diseases such as ringworm, athlete's foot, histoplasmosis, yeast vaginitis, and thrush (figure 14-5). Antibiotics do not kill fungi. Antifungal medications are available for many of the pathogenic fungi, but they are expensive, must be taken internally for a long period, and may cause liver damage.
- ◆ **Rickettsiae:** These are parasitic microorganisms, which means they cannot live outside the cells of another living organism. They are commonly found in fleas, lice, ticks, and mites, and are transmitted to humans by the bites of

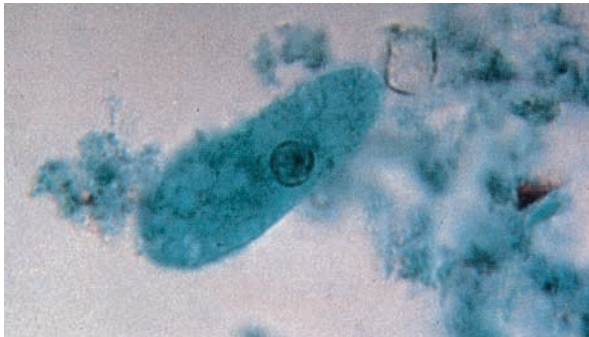

FIGURE 14-4 An intestinal protozoan, *Entamoeba coli*. (Courtesy of the Centers for Disease Control and Prevention, Atlanta, GA)



FIGURE 14-5 The yeast (fungus) called *thrush* causes these characteristic white patches on the tongue.

these insects. Rickettsiae cause diseases such as typhus fever and Rocky Mountain spotted fever. Antibiotics are effective against many different rickettsiae.

- ◆ **Viruses:** These are the smallest microorganisms, visible only using an electron microscope (figure 14-6A and B). They cannot reproduce unless they are inside another living cell. They are spread from human to human by blood and other body secretions. It is important to note that viruses are more difficult to kill because they are resistant to many disinfectants and are not affected by antibiotics. Viruses cause many diseases including the common cold, measles, mumps, chicken pox, herpes, warts, influenza, and polio. New and different viruses emerge constantly because viruses are prone to mutating and changing genetic information. In addition, viruses that infect animals can mutate to infect humans, often with lethal results. There are many examples of these viruses. *Severe acute respi-*

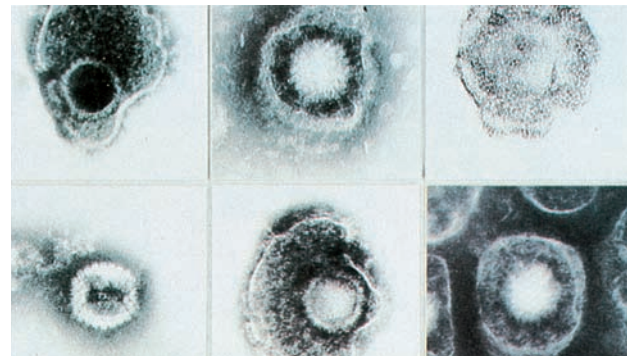

FIGURE 14-6A Electron micrographs of the various types of herpes simplex virus. (Courtesy of the Centers for Disease Control and Prevention, Atlanta, GA)

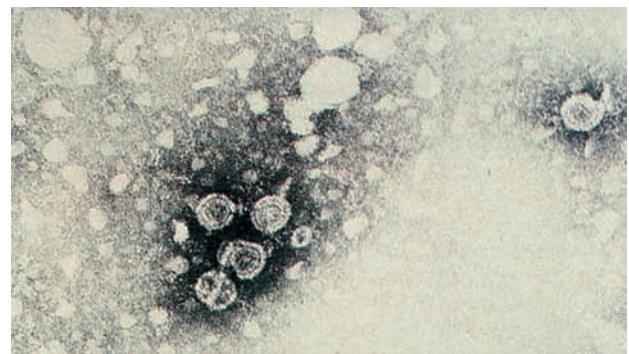

FIGURE 14-6B Electron micrograph of the hepatitis B virus. (Courtesy of the Centers for Disease Control and Prevention, Atlanta, GA)

ratory syndrome (SARS) is caused by a variant of the coronavirus family that causes the common cold. It is characterized by flu-like symptoms that can lead to respiratory failure and death. *West Nile virus (WNV)* is a mosquito-borne flavivirus that first infected birds but now infects humans. In some individuals, it causes only a mild febrile illness. In other individuals who are older or have poor immune systems, it can cause severe neurologic illnesses such as encephalitis or meningitis, which can lead to death. *Monkeypox*, a hantavirus that affects monkeys, other primates, and rodents, mutated and spread to humans. Infection usually occurs after contacting body secretions or excretions (urine and stool) of infected animals or ingesting food that has been contaminated by fluids from infected animals. A major outbreak occurred in the American southwest when infected prairie dogs contaminated food with fecal material. Monkeypox is similar to smallpox. It causes severe flu-like symptoms, lymphadenopathy (disease of the lymph nodes), and pustules that cause severe scarring of the skin. If the eyes are infected, blindness can occur. It can be prevented and/or treated with a smallpox vaccination. Filoviruses such as *Ebola* and *Marburg* first affected primates and then spread to humans. These viruses cause hemorrhagic fever, a disease that begins with fever, chills, headache, myalgia (muscle pain), and a skin rash. It quickly progresses to jaundice, pancreatitis, liver failure, massive hemorrhaging throughout the body, delirium, shock, and death. Most outbreaks of hemorrhagic fever have been in Africa, but isolated cases have appeared in other parts of the world when individuals were in contact with infected primates. A new *H5N1* virus that causes avian or bird flu has devastated bird flocks in many countries. The infection has appeared in humans, but most cases have resulted from contact with infected poultry or contaminated surfaces. The spread from one person to another has been reported only rarely. However, because the death rate for bird flu is between 50 and 60 percent, a major concern is that the *H5N1* virus will mutate and spread more readily. In addition to these viruses, there are three other viral diseases of major concern to the health care worker: hepatitis B, hepatitis C, and acquired immune deficiency syn-

drome (AIDS). **Hepatitis B**, or serum hepatitis, is caused by the HBV virus and is transmitted by blood, serum, and other body secretions. It affects the liver and can lead to the destruction and scarring of liver cells. A vaccine has been developed to protect individuals from this disease. The vaccine is expensive and involves a series of three injections. Under federal law, employers must provide the vaccination at no cost to any health care worker with occupational exposure to blood or other body secretions that may carry the HBV virus. An individual does have the right to refuse the vaccination, but a written record must be kept proving that the vaccine was offered. **Hepatitis C** is caused by the hepatitis C virus, or HCV, and is transmitted by blood and blood-containing body fluids. Many individuals who contract the disease are asymptomatic (display no symptoms); others have mild symptoms that are often diagnosed as influenza or flu. In either case, HCV can cause serious liver damage. At present, there is no preventive immunization, but a vaccine is being developed. Both HBV and HCV are extremely difficult to destroy. These viruses can even remain active for several days in dried blood. Health care workers must take every precaution to protect themselves from hepatitis viruses. **Acquired immune deficiency syndrome** is caused by the human immunodeficiency virus (HIV) and suppresses the immune system. An individual with AIDS cannot fight off many cancers and infections that would not affect a healthy person. Presently, there is no cure and no vaccine is available, so it is important for the health care worker to take precautions to prevent the spread of this disease.

- ◆ **Helminths:** These are multicellular parasitic organisms commonly called *worms* or *flukes*. They are transmitted to humans when humans ingest the eggs or larvae in contaminated food, ingest meat contaminated with the worms, or get bitten by infected insects. Some worms can also penetrate the skin to enter the body. Examples of helminths include: hookworms, which attach to the small intestine and can infect the heart and lungs; ascariasis, which live in the small intestine and can cause an obstruction of the intestine; trichinella spiralis, which causes trichinosis and is contracted by eating raw or inadequately cooked pork

products; enterobiasis, which is commonly called *pinworm* and affects mainly young children; and taenia solium or pork tapeworm, which is contracted by eating inadequately cooked pork.

TYPES OF INFECTION

Pathogenic microorganisms cause infection and disease in different ways. Some pathogens produce poisons, called *toxins*, which harm the body. An example is the bacillus that causes tetanus, which produces toxins that damage the central nervous system. Some pathogens cause an allergic reaction in the body, resulting in a runny nose, watery eyes, and sneezing. Other pathogens attack and destroy the living cells they invade. An example is the protozoan that causes malaria. It invades red blood cells and causes them to rupture.

Infections and diseases are also classified as endogenous, exogenous, nosocomial, or opportunistic. **Endogenous** means the infection or disease originates within the body. These include metabolic disorders, congenital abnormalities, tumors, and infections caused by microorganisms within the body. **Exogenous** means the infection or disease originates outside the body. Examples include pathogenic organisms that invade the body, radiation, chemical agents, trauma, electric shock, and temperature extremes. A **nosocomial** infection is one acquired by an individual in a health care facility such as a hospital or long-term care facility. Nosocomial infections are usually present in the facility and transmitted by health care workers to the patient. Many of the pathogens transmitted in this manner are antibiotic-resistant and can cause serious and even life-threatening infections in patients. Common examples are staphylococcus, pseudomonas, and enterococci. Infection-control programs are used in health care facilities to prevent and deal with nosocomial infections. **Opportunistic** infections are those that occur when the body's defenses are weak. These diseases do not usually occur in individuals with intact immune systems. Examples include the development of Kaposi's sarcoma (a rare type of cancer) or *Pneumocystis carinii* pneumonia in individuals with AIDS.

CHAIN OF INFECTION

For disease to occur and spread from one individual to another, certain conditions must be met. These conditions are commonly called the **chain of infection** (figure 14-7). The parts of the chain include:

- ◆ **Causative agent:** a pathogen, such as a bacterium or virus that can cause a disease
- ◆ **Reservoir:** an area where the causative agent can live; some common reservoirs include the human body, animals, the environment, and **fomites**, or objects contaminated with infectious material that contains the pathogens. Common fomites include doorknobs, bedpans, urinals, linens, instruments, and specimen containers.
- ◆ **Portal of exit:** a way for the causative agent to escape from the reservoir in which it has been growing. In the human body, pathogens can leave the body through urine, feces, saliva, blood, tears, mucous discharge, sexual secretions, and draining wounds.
- ◆ **Mode of transmission:** a way that the causative agent can be transmitted to another reservoir or host where it can live. The pathogen can be transmitted in different ways. One way is by *direct contact*, which includes person-to-person contact (physical or sexual contact) or contact with a body secretion containing the pathogen. Contaminated hands are one of the most common sources of direct contact transmission. Another way is by *indirect contact*, when the pathogen is transmitted from contaminated substances such as food, air, soil, insects, feces, clothing, instruments, and equipment. Examples include touching contaminated equipment and spreading the pathogen on the hands, breathing in droplets carrying airborne infections, and contacting *vectors* (insects, rodents, or small animals), such as being bitten by an insect carrying a pathogen.
- ◆ **Portal of entry:** a way for the causative agent to enter a new reservoir or host. Some ways pathogens can enter the body are through breaks in the skin, breaks in the mucous membrane, the respiratory tract, the digestive tract, the genitourinary tract, and the circulatory system. If the defense mechanisms of the body

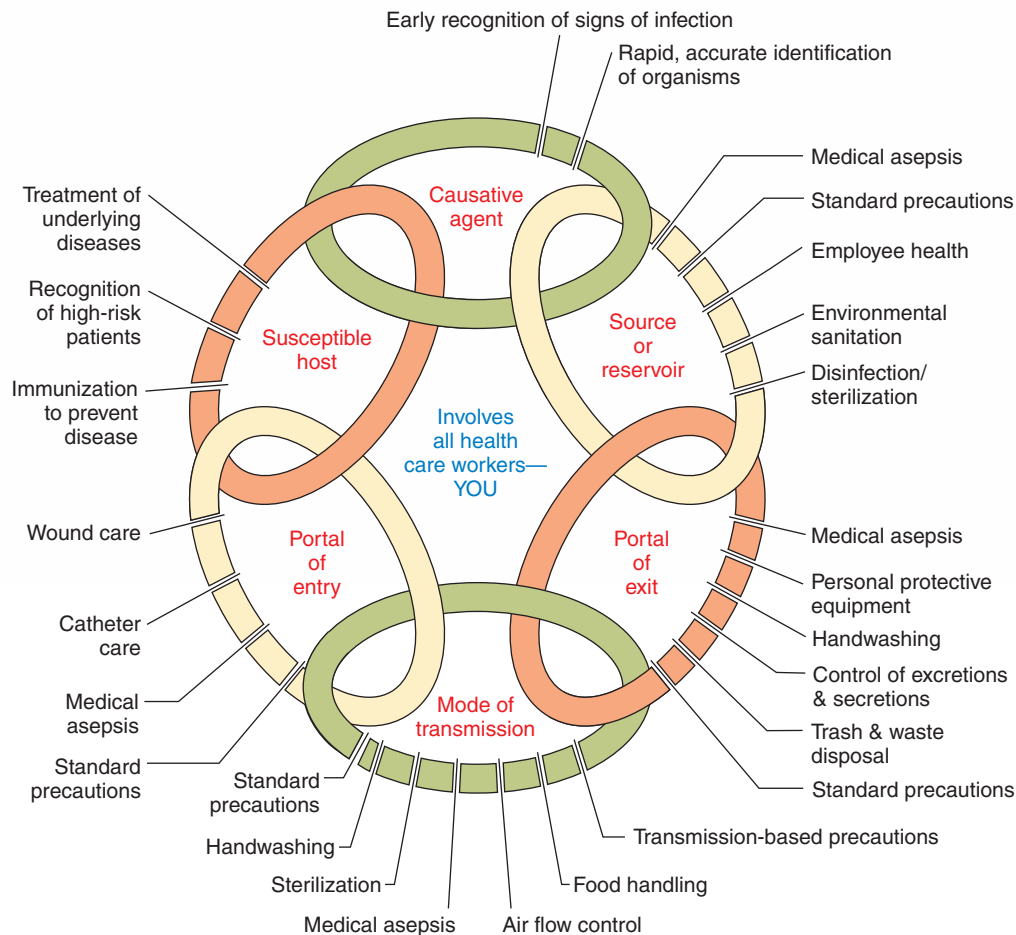

FIGURE 14-7 Note the components in the chain of infection and the ways in which the chain can be broken.

are intact and the immune system is functioning, a human can frequently fight off the causative agent and not contract the disease. Body defenses include:

mucous membrane: lines the respiratory, digestive, and reproductive tracts and traps pathogens

cilia: tiny, hairlike structures that line the respiratory tract and propel pathogens out of the body

coughing and sneezing

hydrochloric acid: destroys pathogens in the stomach

tears in the eye: contain bacteriocidal (bacteria-killing) chemicals

fever

inflammation: leukocytes, or white blood cells, destroy pathogens

immune response: body produces antibodies, protective proteins that combat pathogens, and protective chemicals secreted by cells, such as interferon and complement

◆ **Susceptible host**: a person likely to get an infection or disease, usually because body defenses are weak

Health care workers must constantly be aware of the parts in the chain of infection. If any part of the chain is eliminated, the spread of disease or infection will be stopped. A health care worker who is aware of this can follow practices to interrupt or break this chain and prevent the transmission of disease. It is important to remember that pathogens are everywhere and that preventing their transmission is a continuous process.

ASEPTIC TECHNIQUES

A major way to break the chain of infection is to use aseptic techniques while providing health care. **Asepsis** is defined as the absence of disease-producing microorganisms, or pathogens.

Sterile means free from all organisms, both pathogenic and nonpathogenic, including spores

and viruses. **Contaminated** means that organisms and pathogens are present. Any object or area that may contain pathogens is considered to be contaminated. Aseptic techniques are directed toward maintaining cleanliness and eliminating or preventing contamination. Common aseptic techniques include handwashing, good personal hygiene, use of disposable gloves when contacting body secretions or contaminated objects, proper cleaning of instruments and equipment, and thorough cleaning of the environment.

Various levels of aseptic control are possible. These include:

- ◆ **Antisepsis:** Antiseptics prevent or inhibit growth of pathogenic organisms but are not effective against spores and viruses. They can usually be used on the skin. Common examples include alcohol and betadine.
- ◆ **Disinfection:** This is a process that destroys or kills pathogenic organisms. It is not always effective against spores and viruses. Chemical disinfectants are used in this process. Disinfectants can irritate or damage the skin and are used mainly on objects, not people. Some common disinfectants are bleach solutions and zephiran.
- ◆ **Sterilization:** This is a process that destroys all microorganisms, both pathogenic and nonpathogenic, including spores and viruses. Steam under pressure, gas, radiation, and chemicals can be used to sterilize objects. An autoclave is the most common piece of equipment used for sterilization.

In the sections that follow, correct methods of aseptic techniques are described. It is important for the health care worker to know and use these methods in every aspect of providing health care to prevent the spread and transmission of disease.

STUDENT: Go to the workbook and complete the assignment sheet for 14:1, *Understanding the Principles of Infection Control*.

14:2 INFORMATION

Bioterrorism

INTRODUCTION

Bioterrorism is the use of microorganisms, or biologic agents, as weapons to infect humans, animals, or plants. Throughout history, microor-

ganisms have been used in biologic warfare. Some examples include:

- ◆ The Tartar army throwing bodies of dead plague victims over the walls of a city called Caffa in 1346, causing an epidemic of plague in the city
- ◆ The British army providing Delaware Indians with blankets and handkerchiefs contaminated with smallpox in 1763, resulting in a major outbreak of smallpox among the Indian population
- ◆ The Germans using a variety of animal and human pathogens in World War I
- ◆ The Japanese military using prisoners of war to experiment with many different pathogens in World War II
- ◆ The United States, Canada, the Soviet Union, and the United Kingdom developing biologic weapons programs until the late 1960s
- ◆ The release of sarin gas in Tokyo in 1995
- ◆ The mail attack with anthrax by an unknown individual or individuals in the United States in 2001

Today, there is a major concern that these biologic agents will be used not only in wars, but also against unsuspecting civilians.

BIOLOGIC AGENTS

Many different microorganisms can cause diseases in humans, animals, and plants. However, only a limited number are considered to be ideal for bioterrorism. Six characteristics of the “ideal” microorganism include:

- ◆ Inexpensive and readily available or easy to produce
- ◆ Spread through the air by winds or ventilation systems and inhaled into the lungs of potential victims, or spread by ingesting contaminated food or water
- ◆ Survives sunlight, drying, and heat
- ◆ Causes death or severe disability
- ◆ Easily transmitted from person to person
- ◆ Difficult to prevent and/or has no effective treatment

The Centers for Disease Control and Prevention (CDC) has identified and classified major

bioterrorism agents. High-priority agents that have been identified include:

- ◆ **Smallpox:** Smallpox is a highly contagious infectious disease that is caused by a variola virus. A smallpox vaccination can provide protection against some types of smallpox, but one type, hemorrhagic smallpox, is usually fatal. Until the 1970s, people were vaccinated against smallpox. However, after many years with no reported cases, the vaccinations were no longer required. Now, with the threat of a smallpox bioterrorism attack, the U.S. government has started a new vaccination program. The program encourages first responders, police, fire department, and health care personnel to be vaccinated.
- ◆ **Anthrax:** Anthrax is an infectious disease caused by the spores of bacteria called *Bacillus anthracis*. The spores are highly resistant to destruction and can live in soil for years. Grazing animals such as cattle, sheep, and goats eat the contaminated soil and become infected. Humans develop anthrax by exposure through the skin (cutaneous) (figure 14-8), by eating undercooked or raw infected meat (gastrointestinal), or by inhaling the spores (pulmonary). Cutaneous and gastrointestinal anthrax are usually treated successfully with antibiotics, but some victims die. Inhalation anthrax causes death in more than 80 percent of its victims. An anthrax vaccine is available for prevention. The military has an active vaccination program.



FIGURE 14-8 Cutaneous (skin) anthrax is usually treated successfully with antibiotics. (Courtesy of the Centers for Disease Control Public Image Library)

- ◆ **Plague:** This is an infectious disease that is caused by bacteria called *Yersinia pestis*. Usually plague is transmitted by the bites of infected fleas. In some cases, the organism enters the body through a break in the skin or by contact with tissue of an infected animal. Rats, rock squirrels, prairie dogs, and chipmunks are the most common sources for plague in the United States. If the disease is not treated immediately with antibiotics, the infection spreads to the blood and lungs, and causes death. No vaccine for plague is available in the United States.
- ◆ **Botulism:** Botulism is a paralytic illness caused by a nerve toxin produced by bacteria called *Clostridium botulinum*. Three main types of botulism exist. One type is caused by eating foods that contain the toxin. A second type is caused by the presence of the toxin in a wound or injury to the skin. A third type occurs in infants who eat the spores that then grow in the intestine and release the toxin. The toxin rapidly causes muscle paralysis. If it is not treated with an antitoxin, the paralysis spreads to the respiratory muscles and causes death.
- ◆ **Tularemia:** This is an infectious disease caused by bacteria called *Francisella tularensis*. This bacteria is commonly found in animals such as rats, rabbits, and insects (ticks and deerflies). Humans get the disease through the bite of an infected animal or insect, by eating contaminated food, by drinking contaminated water, or by breathing in the bacteria. The disease causes death if it is not treated with appropriate antibiotics. Currently, the Food and Drug Administration (FDA) is reviewing a vaccine, but it is not available in the United States.
- ◆ **Filoviruses:** A filovirus is an infectious disease that causes severe hemorrhagic fever. Two filoviruses have been identified. They are the Ebola viruses and the Marburg virus. The source of the viruses is still being researched, but the common belief is that the viruses are transmitted from animals such as bats. Once the viruses affect a human, the disease is spread rapidly from person to person by contact with body fluids. No effective treatment exists, and 50–90 percent of infected individuals die.

Many other pathogenic microorganisms can be used in a bioterrorism attack. In fact, any

pathogenic organism could be used in a bioterrorism attack. For this reason, health care workers must be constantly alert to the threat of infection with a biologic agent.

PREPARING FOR BIOTERRORISM

A bioterrorism attack could cause an epidemic and public health emergency. Large numbers of infected people would place a major stress on health care facilities. Fear and panic could lead to riots, social disorder, and disregard for authority. For these reasons, the Bioterrorism Act of 2002 was passed by Congress and signed into law in June 2002. This act requires the development of a comprehensive plan against bioterrorism to increase security in the United States.

Preparing for bioterrorism will involve government at all levels—local, regional, state, and national. Some of the major aspects of preparation include:

- ◆ Community-based surveillance to detect early indications of a bioterrorism attack
- ◆ Notification of the public when a high-risk situation is detected
- ◆ Strict infection-control measures and public education about the measures
- ◆ Funding for studying pathogenic organisms, developing vaccines, researching treatments, and determining preventive actions
- ◆ Strict guidelines and restrictions for purchasing and transporting pathologic microorganisms
- ◆ Mass immunization, especially for military, first responders, police, fire department, and health care personnel
- ◆ Increased protection of food and water supplies
- ◆ Training personnel to properly diagnose and treat infectious diseases
- ◆ Establishing emergency management policies
- ◆ Criminal investigation of possible threats
- ◆ Improving the ability of health care facilities to deal with an attack by increasing emergency department space, preparing decontamination areas, and establishing isolation facilities

- ◆ Improving communications so information on bioterrorism is transmitted quickly and efficiently



Every health care worker must constantly be alert to the threat of bioterrorism. In today's world, it is likely that an attack will occur. Careful preparation and thorough training can limit the effect of the attack and save the lives of many people.

STUDENT: Go to the workbook and complete the assignment sheet for 14:2, *Bioterrorism*.

14:3 INFORMATION



Washing Hands

  Handwashing is a basic task required in any health occupation. The method described in this unit has been developed to ensure that a thorough cleansing occurs. An aseptic technique is a method followed to prevent the spread of germs or pathogens. *Handwashing is the most important method used to practice aseptic technique.* Handwashing is also the most effective way to prevent the spread of infection.

The hands are a perfect medium for the spread of pathogens. Thoroughly washing the hands helps prevent and control the spread of pathogens from one person to another. It also helps protect the health worker from disease and illness.

The Centers for Disease Control and Prevention (CDC) published the results of handwashing research and new recommendations for hand hygiene in 2002. The recommendations call for regular handwashing using plain soap and water, antiseptic handwashing using an antimicrobial soap and water, and antiseptic hand rubs (waterless handwashing) using alcohol-based hand cleaners. Regular handwashing is recommended for routine cleansing of the hands when the hands are visibly dirty or soiled with blood or other body fluids. Antiseptic handwashing is recommended before invasive procedures, in critical care units, while caring for patients on specific organism transmission-based precautions, and in specific circumstances defined by the infection-control program of the health care facility. Antiseptic hand rubs are recommended if the hands are not visibly dirty or are not soiled with blood or body fluids.

Handwashing should be performed frequently. It should be done:

- ◆ When you arrive at the facility and immediately before leaving the facility
- ◆ Before and after every patient contact
- ◆ After contact with a patient's intact skin (for example, after taking a blood pressure)
- ◆ Before moving from a contaminated body site to a clean body site during patient care (for example, before washing the patient's hands after removing a bedpan)
- ◆ Any time the hands become contaminated during a procedure
- ◆ Before applying and immediately after removing gloves
- ◆ Any time gloves are torn or punctured
- ◆ Before and after handling any specimen
- ◆ After contact with any soiled or contaminated item
- ◆ After picking up any item off the floor
- ◆ After personal use of the bathroom
- ◆ After you cough, sneeze, or use a tissue
- ◆ Before and after any contact with your mouth or mucous membrane, such as eating, drinking, smoking, applying lip balm, or inserting or removing contact lenses

The recommended method for handwashing is based on the following principles; they should be observed whenever hands are washed:

- ◆ Soap is used as a cleansing agent because it aids in the removal of germs through its sudsy action and alkali content. Pathogens are trapped in the soapsuds and rinsed away. Liquid soap from a dispenser should be used whenever possible because bar soap can contain microorganisms.
- ◆ Warm water should be used. This is less damaging to the skin than hot water. It also creates a better lather with soap than does cold water.
- ◆ Friction must be used in addition to soap and water. This action helps rub off pathogens from the surface of the skin.
- ◆ All surfaces on the hands must be cleaned. This includes the palms, the backs/tops of the hands, and the areas between the fingers.
- ◆ Fingertips must be pointed downward. The downward direction prevents water from getting on the forearms and then running down to contaminate the clean hands.

- ◆ Dry paper towels must be used to turn the faucet on and off. This action prevents contamination of the hands from pathogens on the faucet. A dry towel must be used because pathogens can travel more readily through a wet towel.

Nails also harbor dirt and pathogens, and must be cleaned during the handwashing process. An orange/cuticle stick can be used. Care must be taken to use the blunt end of the stick because the pointed end can injure the nailbeds. A brush can also be used to clean the nails. If a brush or orange stick is not available or the nails are not visibly dirty, the nails can be rubbed against the palm of the opposite hand to get soap under the nails. Most health care facilities prohibit the use of artificial nails and require that nails be kept short, usually less than 1/4-inch long. Artificial or long nails can harbor organisms and increase the risk for infection for both the patient and health care worker. In addition, long nails can puncture or tear gloves.

Waterless hand cleaning with an alcohol-based gel, lotion, or foam has been proved safe for

Image not available due to copyright restrictions

use during routine patient care. Its use is recommended when the hands are not visibly dirty and are not contaminated with blood or body fluids (figure 14-9). Most waterless hand cleaning products contain alcohol to provide antiseptics and a moisturizer to prevent drying of the skin. It is important to read the manufacturer's instructions before using any product. Usually a small amount of the alcohol-based cleaner is applied to the palm of the hands. The hands are then rubbed vigorously so the solution is applied to all surfaces of the hands, fingers, nails, and wrists. The hands should be rubbed until they are dry, usually at least 15 seconds. Most manufacturers recommend that

the hands be washed with soap and water after 6–10 cleanings with the alcohol-based product. In addition, if the hands are visibly soiled, or if there has been contact with blood or body fluid, the hands must be washed with soap and water.

Every health care facility has written policies for hand hygiene as a part of their standard precautions manual. Health care workers must become familiar with and follow these policies to prevent the spread of infection.

STUDENT: Go to the workbook and complete the assignment sheet for 14:3, *Washing Hands*. Then return and continue with the procedure.

PROCEDURE 14:3

Washing Hands

Equipment and Supplies

Paper towels, running water, waste container, hand brush or orange/cuticle stick, soap

Procedure

1. Assemble all equipment. Stand back slightly from the sink so you do not contaminate your uniform or clothing. Avoid touching the inside of the sink with your hands since it is considered contaminated. Remove any rings and push your wristwatch up above your wrist.
2. Turn the faucet on by holding a paper towel between your hand and the faucet (figure 14-10A). Regulate the temperature of the water and let water flow over your hands. Discard the towel in the waste container.

NOTE: Water should be warm.

 **CAUTION:** Hot water will burn your hands.

3. With your fingertips pointing downward, wet your hands.

NOTE: Washing in a downward direction prevents water from getting on the

forearms and then running back down to contaminate hands.

4. Use soap to get a lather on your hands.
5. Put the palms of your hands together and rub them using friction and a circular motion for at least 15 seconds.
6. Put the palm of one hand on the back of the other hand. Rub together several times. Repeat this after reversing position of hands (figure 14-10B).
7. Interlace the fingers on both hands and rub them back and forth (figure 14-10C).
8. Encircle your wrist with the palm and fingers of the opposite hand. Use a circular motion to clean the front, back, and sides of the wrist. Repeat for the opposite wrist.
9. Clean the nails with an orange/cuticle stick and/or hand brush if they are visibly dirty or if this is the first hand cleaning of the day (figures 14-10D and E). If the nails are not visibly dirty, they can be cleaned by rubbing them against the palm of the opposite hand.

 **CAUTION:** Use the blunt end of orange/cuticle stick to avoid injury.

NOTE: Steps 3 through 9 ensure that all parts of both hands are clean.

PROCEDURE 14:3



FIGURE 14-10A Use a dry towel to turn the faucet on.



FIGURE 14-10B Point the fingertips downward and use the palm of one hand to clean the back of the other hand.



FIGURE 14-10C Interlace the fingers to clean between the fingers.



FIGURE 14-10D The blunt end of an orange stick can be used to clean the nails.



FIGURE 14-10E A hand brush can also be used to clean the nails.



FIGURE 14-10F With the fingertips pointing downward, rinse the hands thoroughly.

10. Rinse your hands from the forearms down to the fingertips, keeping fingertips pointed downward (figure 14-10F).
11. Use a clean paper towel to dry hands thoroughly, from tips of fingers to wrist. Discard the towel in the waste container.
12. Use another dry paper towel to turn off the faucet.

 **CAUTION:** Wet towels allow passage of pathogens.

13. Discard all used towels in the waste container. Leave the area neat and clean.
14. Apply a water-based hand lotion if desired.

Practice

Go to the workbook and use the evaluation sheet for 14:3, Washing Hands, to practice this procedure. When you believe you have mastered this skill, sign the sheet and give it to your instructor for further action.





Final Checkpoint Using the criteria listed on the evaluation sheet, your instructor will grade your performance.

14:4 Information



Observing Standard Precautions

  To prevent the spread of pathogens and disease, the chain of infection must be broken. The standard precautions discussed in this unit are an important way health care workers can break this chain.

BLOODBORNE PATHOGENS STANDARD

One of the main ways that pathogens are spread is by blood and body fluids. Three pathogens of major concern are the hepatitis B virus (HBV), the hepatitis C virus (HCV), and the human immunodeficiency virus (HIV), which causes AIDS. Consequently, extreme care must be taken at all times when an area, object, or person is contaminated with blood or body fluids. In 1991, the Occupational Safety and Health Administration (OSHA) established *Bloodborne Pathogen Standards* that must be followed by all health care facilities. The employer faces civil penalties if the regulations are not implemented by the employer and followed by the employees. These regulations require all health care facility employers to:

- ◆ Develop a written exposure control plan, and update it annually, to minimize or eliminate employee exposure to bloodborne pathogens.
- ◆ Identify all employees who have occupational exposure to blood or potentially infectious materials such as semen, vaginal secretions, and other body fluids.
- ◆ Provide hepatitis B vaccine free of charge to all employees who have occupational exposure, and obtain a written release form signed by any employee who does not want the vaccine.
- ◆ Provide **personal protective equipment (PPE)** such as gloves, gowns, lab coats, masks, and face shields in appropriate sizes and in accessible locations.
- ◆ Provide adequate handwashing facilities and supplies.
- ◆ Ensure that the worksite is maintained in a clean and sanitary condition, follow measures for immediate decontamination of any sur-

face that comes in contact with blood or infectious materials, and dispose of infectious waste correctly.

- ◆ Enforce rules of no eating, drinking, smoking, applying cosmetics or lip balm, handling contact lenses, and mouth pipetting or suctioning in any area that can be potentially contaminated by blood or other body fluids.
- ◆ Provide appropriate containers that are color coded (fluorescent orange or orange-red) and labeled for contaminated sharps (needles, scalpels) and other infectious or biohazard wastes.
- ◆ Post signs at the entrance to work areas where there is occupational exposure to biohazardous materials. Label any item that is biohazardous with the red biohazard symbol (figure 14-11). The label must show both the symbol and the word “biohazard.”
- ◆ Provide a confidential medical evaluation and follow-up for any employee who has an exposure incident. Examples might include an accidental needlestick or the splashing of blood or body fluids on the skin, eyes, or mucous membranes.
- ◆ Provide training about the regulations and all potential biohazards to all employees at no cost during working hours, and provide additional education as needed when procedures or working conditions are changed or modified.

NEEDLESTICK SAFETY ACT

In 2001, OSHA revised its Bloodborne Pathogen Standards in response to Congress passing the *Needlestick Safety and Prevention Act* in Novem-



FIGURE 14-11 The universal biohazard symbol indicates a potential source of infection.

ber 2000. This act was passed after the Centers for Disease Control and Prevention (CDC) estimated that 600,000 to 800,000 needlesticks occur each year, exposing health care workers to bloodborne pathogens. Employers are required to:

- ◆ *Identify and use effective and safer medical devices.* OSHA defines safer devices as sharps with engineered injury protections and includes, but is not limited to, devices such as syringes with a sliding sheath that shields the needle after use, needles that retract into a syringe after use, shielded or retracting catheters that can be used to administer intravenous medications or fluids, and intravenous systems that administer medication or fluids through a catheter port or connector site using a needle housed in a protective covering (figure 14-12). OSHA also encourages the use of needleless systems, which include, but are not limited to, intravenous medication delivery systems that administer medication or fluids through a catheter port or connector site using a blunt cannula or other non-needle connection, and jet injection systems that deliver subcutaneous or intramuscular injections through the skin without using a needle.



FIGURE 14-12 The Safety-Glide syringe is one example of a safer device to prevent needlesticks. (Photo reprinted courtesy of BD [Becton Dickinson and Company])

- ◆ *Incorporate changes in annual update of exposure control plan.* Employers must include changes in technology that eliminate or reduce exposure to bloodborne pathogens in the annual update and document the implementation of any safer medical devices.
- ◆ *Solicit input from nonmanagerial employees who are responsible for direct patient care.* Employees who provide patient care, and are exposed to injuries from contaminated sharps, must be included in a multidisciplinary team that identifies, evaluates, and selects safer medical devices, and determines safer work practice controls.
- ◆ *Maintain a sharps injury log.* Employers with more than 11 employees must maintain a sharps injury log to help identify high-risk areas and evaluate ways of decreasing injuries. Each injury recorded must protect the confidentiality of the injured employee, but must state the type and brand of device involved in the incident, the work area or department where the exposure injury occurred, and a description of how the incident occurred.

STANDARD PRECAUTIONS

Employers are also required to make sure that every employee uses standard precautions at all times to prevent contact with blood or other potentially infectious materials. **Standard precautions** (figure 14-13) are rules developed by the CDC. According to standard precautions, every body fluid must be considered a potentially infectious material, and all patients must be considered potential sources of infection, regardless of their disease or diagnosis. Standard precautions must be used in any situation where health care providers may contact:

- ◆ Blood or any fluid that may contain blood
- ◆ Body fluids, secretions, and excretions, such as mucus, sputum, saliva, cerebrospinal fluid, urine, feces, vomitus, amniotic fluid (surrounding a fetus), synovial (joint) fluid, pleural (lung) fluid, pericardial (heart) fluid, peritoneal (abdominal cavity) fluid, semen, and vaginal secretions

STANDARD PRECAUTIONS

FOR INFECTION CONTROL



Wash Hands (Plain soap)

Wash after touching **blood, body fluids, secretions, excretions, and contaminated items**. Wash immediately **after gloves are removed** and **between patient contacts**. Avoid transfer of microorganisms to other patients or environments.



Wear Gloves

Wear when touching **blood, body fluids, secretions, excretions, and contaminated items**. Put on **clean** gloves just **before touching mucous membranes** and **nonintact skin**. Change gloves between tasks and procedures on the same patient after contact with material that may contain high concentrations of microorganisms. Remove gloves promptly after use, before touching noncontaminated items and environmental surfaces, and before going to another patient, and wash hands immediately to avoid transfer of microorganisms to other patients or environments.



Wear Mask and Eye Protection or Face Shield

Protect mucous membranes of the eyes, nose and mouth during procedures and patient-care activities that are likely to generate **splashes** or **sprays** of **blood, body fluids, secretions, or excretions**.



Wear Gown

Protect skin and prevent soiling of clothing during procedures that are likely to generate **splashes** or **sprays** of **blood, body fluids, secretions, or excretions**. Remove a soiled gown as promptly as possible and wash hands to avoid transfer of microorganisms to other patients or environments.



Patient-Care Equipment

Handle used patient-care equipment soiled with **blood, body fluids, secretions, or excretions** in a manner that prevents skin and mucous membrane exposures, contamination of clothing, and transfer of microorganisms to other patients and environments. Ensure that reusable equipment is not used for the care of another patient until it has been appropriately cleaned and reprocessed and single use items are properly discarded.



Environmental Control

Follow hospital procedures for routine care, cleaning, and disinfection of environmental surfaces, beds, bedrails, bedside equipment and other frequently touched surfaces.



Linen

Handle, transport, and process used linen soiled with **blood, body fluids, secretions, or excretions** in a manner that prevents exposures and contamination of clothing, and avoids transfer of microorganisms to other patients and environments.



Occupational Health and Bloodborne Pathogens

Prevent injuries when using needles, scalpels, and other sharp instruments or devices; when handling sharp instruments after procedures; when cleaning used instruments; and when disposing of used needles.

Never recap used needles using both hands or any other technique that involves directing the point of a needle toward any part of the body; rather, use either a one-handed "scoop" technique or a mechanical device designed for holding the needle sheath.

Do not remove used needles from disposable syringes by hand, and do not bend, break, or otherwise manipulate used needles by hand. Place used disposable syringes and needles, scalpel blades, and other sharp items in puncture-resistant sharps containers located as close as practical to the area in which the items were used, and place reusable syringes and needles in a puncture-resistant container for transport to the reprocessing area.

Use **resuscitation devices** as an alternative to mouth-to-mouth resuscitation.



Patient Placement

Use a **private room** for a patient who contaminates the environment or who does not (or cannot be expected to) assist in maintaining appropriate hygiene or environmental control. Consult Infection Control if a private room is not available.

The information on this sign is abbreviated from the HICPAC Recommendations for Isolation Precautions in Hospitals.

Form No. **SPR**
BREVIS CORP., 3310 S 2700 E, SLC, UT 84109
© 1996 Brevis Corp.

FIGURE 14-13 Standard precautions must be observed while working with all patients. (Courtesy of Brevis Corporation)

- ◆ Mucous membranes
- ◆ Nonintact skin
- ◆ Tissue or cell specimens

The basic rules of standard precautions include:

- ◆ **Handwashing:** Hands must be washed before and after contact with any patient. If hands or other skin surfaces are contaminated with blood, body fluids, secretions, or excretions, they must be washed immediately and thoroughly with soap and water. Hands must always be washed immediately before donning and immediately after removal of gloves.
- ◆ **Gloves:** Gloves (figure 14-14) must be worn whenever contact with blood, body fluids, secretions, excretions, mucous membranes, tissue specimens, or nonintact skin is possible; when handling or cleaning any contaminated items or surfaces; when performing any invasive (entering the body) procedure; and when performing venipuncture or blood tests. Rings must be removed before putting on gloves to avoid puncturing the gloves. Gloves must be changed after contact with each patient and even between tasks or procedures on the same patient if there is any chance the gloves are contaminated. Hands must be washed immediately after removal of gloves.



FIGURE 14-14 Gloves must be worn whenever contact with blood, body fluids, secretions, excretions, mucous membranes, or nonintact skin is possible.

Care must be taken while removing gloves to avoid contamination of the skin. Gloves must *not* be washed or disinfected for reuse because washing may allow penetration of liquids through undetected holes, and disinfecting agents may cause deterioration of gloves.

- ◆ **Gowns:** Gowns must be worn during any procedure that is likely to cause splashing or spraying of blood, body fluids, secretions, or excretions. This helps prevent contamination of clothing or uniforms. Contaminated gowns must be handled according to agency policy and local and state laws. Wash hands immediately after removing a gown.
- ◆ **Masks and Eye Protection:** Masks and protective eyewear or face shields (figure 14-15) must be worn during procedures that may produce splashes or sprays of blood, body fluids, secretions, or excretions. Examples include irriga-



FIGURE 14-15 Gloves, a gown, a mask, and protective eyewear must be worn during any procedure that may produce droplets or cause splashing of blood, body fluids, secretions, or excretions.

tion of wounds, suctioning, dental procedures, delivery of a baby, and surgical procedures. This prevents exposure of the mucous membranes of the mouth, nose, and eyes to any pathogens.

Masks must be used once and then discarded. In addition, masks should be changed every 30 minutes or anytime they become moist or wet. They should be removed by grasping the ties or elastic strap. Hands must be washed immediately after the mask is removed. Protective eyewear or face shields should provide protection for the front, top, bottom, and sides of the eyes. If eyewear is not disposable, it must be cleaned and disinfected before it is reused.

- ◆  **Sharps:** To avoid accidental cuts or punctures, extreme care must be taken while handling sharp objects. Whenever possible, safe needles or needleless devices must be used. Disposable needles must never be bent or broken after use. They must be left uncapped and attached to the syringe and placed in a leakproof puncture-resistant sharps container (figure 14-16). The sharps container must be



FIGURE 14-16 All needles and sharp objects must be discarded immediately in a leakproof puncture-resistant sharps container.

labeled with a red biohazard symbol. Surgical blades, razors, and other sharp objects must also be discarded in the sharps container.

- ◆  The sharps containers must *not* be emptied or reused. Federal, state, and local laws establish regulations for the disposal of sharps containers. In some areas, the filled container is placed in a special oven and melted. The material remaining is packaged as biohazard or infectious waste and disposed of according to legal requirements for infectious waste.
- ◆ **Spills or Splashes:** Spills or splashes of blood, body fluids, secretions, or excretions must be wiped up immediately (figure 14-17). Gloves must be worn while wiping up the area with disposable cleaning cloths. The area must then be cleaned with a disinfectant solution such as a 10-percent bleach solution. Furniture or equipment contaminated by the spill or splash must be cleaned and disinfected immediately. For large spills, an absorbent powder may be used to soak up the fluid. After the fluid is absorbed, it is swept up and placed in an infectious waste container.



FIGURE 14-17 Gloves must be worn while wiping up any spills of blood, body fluids, secretions, or excretions.

- ◆ **Resuscitation Devices:** Whenever possible, mouthpieces or resuscitation devices should be used to avoid the need for mouth-to-mouth resuscitation. These devices should be placed in convenient locations and be readily accessible for use.
- ◆ **Waste and Linen Disposal:** Health care workers must wear gloves and follow the agency policy developed according to law to dispose of waste and soiled linen. Infectious wastes such as contaminated dressings; gloves; urinary drainage bags; incontinent pads; vaginal pads; disposable emesis basins, bedpans, and/or urinals; and body tissues must be placed in special infectious waste or biohazardous material bags (figure 14-18) according to law. Other trash is frequently placed in plastic bags and incinerated. The health care worker must dispose of waste in the proper

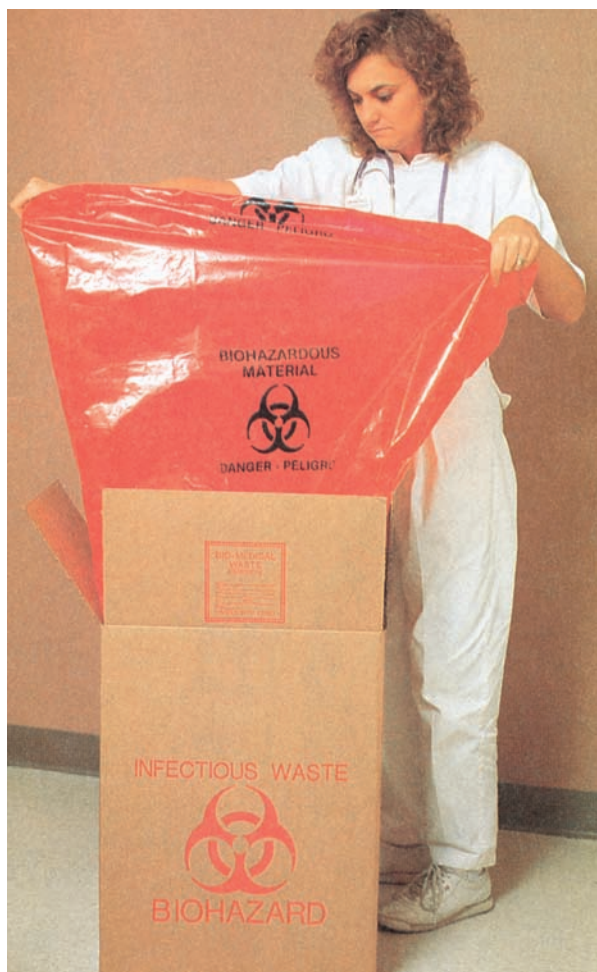

FIGURE 14-18 All infectious wastes must be placed in special infectious waste or biohazardous material bags.

container (figure 14-19) and know the requirements for disposal. Soiled linen should be placed in laundry bags to prevent any contamination. Linen soiled with blood, body fluids, or excretions is placed in a special bag for contaminated linen and is usually soaked in a disinfectant prior to being laundered. Gloves must be worn while handling any contaminated linen, and any bag containing contaminated linen must be clearly labeled and color coded.

- ◆ **Injuries:** Any cut, injury, needlestick, or splashing of blood or body fluids must be reported immediately. Agency policy must be followed to deal with the injury or contamination. Every health care facility must have a policy for stating actions that must be taken immediately when exposure or injury occurs, reporting any incident, documenting any exposure incident, recording the care given, noting follow-up to the exposure incident, and identifying ways to prevent a similar incident.

Standard precautions must be followed at all times by all health care workers. By observing these precautions, health care workers can help break the chain of infection and protect themselves, their patients, and all other individuals.

STUDENT: Go to the workbook and complete the assignment sheet for 14:4, *Observing Standard Precautions*. Then return and continue with the procedure.



FIGURE 14-19 The health care worker must know the requirements for disposal of waste materials and dispose of wastes in the proper containers.

PROCEDURE 14:4

Observing Standard Precautions

Equipment and Supplies

Disposable gloves, infectious waste bags, needle and syringe, sharps container, gown, masks, protective eyewear, resuscitation devices

NOTE: This procedure will help you learn standard precautions. It is important for you to observe these precautions at all times while working in the laboratory or clinical area.

Procedure

1. Assemble equipment.
2. Review the precautions in the information section for Observing Standard Precautions. Note points that are not clear, and ask your instructor for an explanation.
3. Practice handwashing according to Procedure 14:3. Identify at least six times that hands must be washed according to standard precautions.
4. Name four instances when gloves must be worn to observe standard precautions. Put on a pair of disposable gloves. Practice removing the gloves without contaminating the skin. With a gloved hand, grasp the cuff of the glove on the opposite hand, handling only the outside of the glove (figure 14-20A). Pull the glove down and turn it inside out while removing it. Take care not to touch the skin with the gloved hand. Using the ungloved hand, slip the fingers under the cuff of the glove on the opposite hand (figure 14-20B). Touching only the inside of the glove and taking care not to touch the skin, pull the glove down and turn it inside out while removing it. Place the gloves in an infectious waste container. Wash your hands immediately.
5. Practice putting on a gown. State when a gown is to be worn. To remove the gown, touch only the inside. Fold the contaminated gown so the outside is folded inward. Roll it into a bundle and place it in an infectious waste container if it is disposable, or in a bag for contaminated linen if it is not disposable.



FIGURE 14-20A To remove the first glove, use a gloved hand to grasp the outside of the glove on the opposite hand. Pull the glove down and turn it inside out while removing it.



FIGURE 14-20B To remove the second glove, slip the fingers of the ungloved hand inside the cuff of the glove. Touch only the inside of the glove while pulling it down and turning it inside out.

PROCEDURE 14:4

CAUTION: If a gown is contaminated, gloves should be worn while removing the gown.

NOTE: Folding the gown and rolling it prevents transmission of pathogens.

6. Practice putting on a mask and protective eyewear. To remove the mask, handle it by the ties only. Clean and disinfect protective eyewear after use.
7. Practice proper disposal of sharps. Uncap a needle attached to a syringe, taking care not to stick yourself with the needle. Place the entire needle and syringe in a sharps container. State the rules regarding disposal of the sharps container.
8. Spill a small amount of water on a counter. Pretend that it is blood. Put on gloves and use disposable cloths or gauze to wipe up the spill. Put the contaminated cloths or gauze in an infectious waste bag. Use clean disposable cloths or gauze to wipe the area thoroughly with a disinfectant agent. Put the cloths or gauze in the infectious waste bag,



FIGURE 14-21A To close an infectious waste bag, wear gloves and place your hands under the cuff to gently expel excess air.

remove your gloves, and wash your hands.

9. Practice handling an infectious waste bag. Fold down the top edge of the bag to form a cuff at the top of the bag. Wear gloves to close the bag after contaminated wastes have been placed in it. Put your hands under the folded cuff (figure 14-21A) and gently expel excess air from the bag. Twist the top of the bag shut and fold down the top edges to seal the bag. Secure the fold with tape or a tie according to agency policy (figure 14-21B).
10. Examine mouthpieces and resuscitation devices that can be used in place of mouth-to-mouth resuscitation. You will be taught to use these devices when you learn cardiopulmonary resuscitation (CPR).
11. Discuss the following situations with another student and determine which standard precautions should be observed:
 - A patient has an open sore on the skin and pus is seeping from the area. You are going to bathe the patient.
 - You are cleaning a tray of instruments that contains a disposable surgical blade and needle with syringe.



FIGURE 14-21B After folding down the top edge of the infectious waste bag, tie or tape it securely.

PROCEDURE 14:4

- A tube of blood drops to the floor and breaks, spilling the blood on the floor.
- Drainage from dressings on an infected wound has soiled the linen on the bed you are changing.
- You work in a dental office and are assisting a dentist while a tooth is being extracted (removed).

12. Replace all equipment used.

Practice

Go to the workbook and use the evaluation sheet for 14:4, Observing Standard Precautions. When you believe you have mastered this skill, sign the sheet and give it to your instructor for further action.



Final Checkpoint Using the criteria listed on the evaluation sheet, your instructor will grade your performance.

14:5 Information



Sterilizing with an Autoclave

Sterilization of instruments and equipment is essential in preventing the spread of infection. In any of the health fields, you may be responsible for proper sterilization. The following basic principles relate to sterilization methods. The autoclave is the safest, most efficient sterilization method.

An **autoclave** is a piece of equipment that uses steam under pressure or gas to sterilize equipment and supplies (figure 14-22). It is the most efficient method of sterilizing most articles,



FIGURE 14-22 An autoclave uses steam under pressure to sterilize items.

and it will destroy all microorganisms, both pathogenic and nonpathogenic, including spores and viruses.

Autoclaves are available in various sizes and types. Offices and health clinics usually have smaller units, and hospitals or surgical areas have large floor model units. A pressure cooker can be used in home situations.

Before any equipment or supplies are sterilized in an autoclave, they must be prepared properly. All items must be washed thoroughly and then rinsed. Oily substances can often be removed with alcohol or ether. Any residue left on articles will tend to bake and stick to the article during the autoclaving process.

Items that are to remain sterile must be wrapped before they are autoclaved. A wide variety of wraps are available. The wrap must be a material that will allow for the penetration of steam during the autoclaving process. Samples of wraps include muslin, autoclave paper, special plastic or paper bags, and autoclave containers (figure 14-23).

Autoclave indicators are used to ensure that articles have been sterilized (figure 14-24). Examples of indicators include autoclave tape, sensitivity marks on bags or wraps, and indicator capsules. The indicator is usually placed on or near the article when the article is put into the autoclave. Indicators can also be placed in the center of a package, such as a tray of instruments, to show that sterilization of the entire package has occurred. The indicator will change appear-



FIGURE 14-23 Special plastic or paper autoclave bags can be used to sterilize instruments.



FIGURE 14-24 Autoclave indicators change color to show that sterilization has occurred. The strips below each package show how the indicators looked before sterilization.

ance during the autoclaving process because of time and temperature, which leads to sterilization. Learn how to recognize that an article is sterile by reading the directions provided with indicators.

The autoclave must be loaded correctly for all parts of an article to be sterilized. Steam builds at

the top of the chamber and moves downward. As it moves down, it pushes cool, dry air out of the bottom of the chamber. Therefore, materials must be placed so the steam can penetrate along the natural planes between the packages of articles in the autoclave. Place the articles in such a way that there is space between all pieces. Packages should be placed on the sides, not flat. Jars, basins, and cans should be placed on their sides, not flat, so that steam can enter and air can flow out. No articles should come in contact with the sides, top, or door of the autoclave.

The length of time and amount of pressure required to sterilize different items varies (figure 14-25). *It is important to check the directions that come with the autoclave.* Because different types of articles require different times and pressures, it is important to separate loads so that all articles sterilized at one time require the same time and pressure. For example, rubber tubings usually require a relatively short period of time and can

Articles	Time at 250° to 254°F (121° to 123°C)
Glassware: empty, inverted	15 minutes
Instruments: metal in covered or open, padded or unpadded tray	
Needles, unwrapped	
Syringes: unassembled, unwrapped	
Instruments, metal combined with other materials in covered and/or padded tray	
Instruments wrapped in double-thickness muslin	20 minutes
Flasked solutions, 75–250 mL	
Needles, individually packaged in glass tubes or paper	
Syringes: unassembled, individually packed in muslin or paper	30 minutes
Dressings wrapped in paper or muslin (small packs only)	
Flasked solutions, 500–1,000 mL	
Sutures: silk, cotton, or nylon; wrapped in paper or muslin	
Treatment trays wrapped in muslin or paper	

FIGURE 14-25 The length of time required to sterilize different items varies.

be damaged by long exposure. Certain instruments and needles require a longer period of time to ensure sterilization; therefore, items of this type should not be sterilized in the same load as are rubber tubings.

Wet surfaces permit rapid infiltration of organisms, so it is important that all items are thoroughly dry before being removed from the autoclave. The length of time for drying varies. Follow the manufacturer's instructions.

Sterilized items must be stored in clean, dust-proof areas. Items usually remain sterile for 30 days after autoclaving. However, if the wraps loosen or tear, if they become wet, or if any chance of contamination occurs, the items should be rewrapped and autoclaved again.

NOTE: At the end of the 30-day sterile period—providing that the wrap has not loosened, been torn, or gotten wet—remove the old autoclave tape from the package, replace with a new, dated tape, and resterilize according to correct procedure.

Some autoclaves are equipped with a special door that allows the autoclave to be used as a dry-heat sterilizer. Dry heat involves the use of a high temperature for a long period of time. The temperature is usually a minimum of 320–350°F (160–177°C). The minimum time is usually 60 minutes. Dry-heat sterilization is a good method

for sterilizing instruments that may corrode, such as knife blades, or items that would be destroyed by the moisture in steam sterilization, such as powders. Dry heat should never be used on soft rubber goods because the heat will destroy the rubber. Some types of plastic will also melt in dry heat. An oven can be used for dry-heat sterilization in home situations.

Procedures 14:5A and 14:5B describe wrapping articles for autoclaving and autoclaving techniques. These procedures vary in different agencies and areas, but the same principles apply. In some facilities, many supplies are purchased as sterile, disposable items; needles and syringes are purchased in sterilized wraps, used once, and then destroyed. In other facilities, however, special treatment trays are sterilized and used more than one time.

It is important that you follow the directions specific to the autoclave with which you are working as well as the agency policy for sterile supplies. Careless autoclaving permits the transmission of disease-producing organisms. Infection control is everyone's responsibility.

STUDENT: Go to the workbook and complete the assignment sheet for 14:5, *Sterilizing with an Autoclave*. Then return and continue with the procedures.

PROCEDURE 14:5A

Wrapping Items for Autoclaving

Equipment and Supplies

Items to wrap: instrument, towel, bowl; autoclave wrap: paper, muslin, plastic or paper bag; autoclave tape or indicator; disposable or utility gloves; pen or autoclave marker; masking tape (if autoclave tape is not used)

Procedure

1. Assemble equipment.
2. Wash hands. Put on gloves.



CAUTION: If the items to be autoclaved are contaminated with blood, body fluids, or tissues, gloves must be worn while cleaning the items.

3. Sanitize the items to be sterilized. Instruments, bowls, and similar items should be cleaned thoroughly in soapy water (figure 14-26). Rinse the items well in cool water to remove any soapy residue. Then rinse well with hot water. Dry the items with a towel. After the items are sanitized and dry, remove the gloves and wash hands.

NOTE: If stubborn stains are present, it may be necessary to soak the items.

PROCEDURE 14:5A



FIGURE 14-26 Wear gloves to scrub instruments thoroughly with soapy water.

NOTE: Check the teeth on serrated (notched like a saw) instruments. Scrub with a brush as necessary.

4. To prepare linen for wrapping, check first to make sure it is clean and dry. Fold the linen in half lengthwise. If it is very wide, fold lengthwise again. Fanfold or accordion pleat the linen from end to



FIGURE 14-27A Fanfold clean, dry linen so all the folds are the same size.

end until a compact package is formed (figure 14-27A). All folds should be the same size. Fold back one corner on the top fold (figure 14-27B). This provides a piece to grab when opening the linen.

NOTE: Fanfolding linens allows for easy handling after sterilization.

5. Select the correct wrap for the item. Make sure the wrap is large enough to enclose the item to be wrapped.

NOTE: Double-thickness muslin, disposable paper wraps, and plastic or paper bags are the most common wraps.

6. With the wrap positioned at a diagonal angle and one corner pointing toward you, place the item to be sterilized in the center of the wrap.

NOTE: Make sure that hinged instruments are open so the steam can sterilize all edges.

7. Fold up the bottom corner to the center (figure 14-28A). Double back a small corner (figure 14-28B).
8. Fold a side corner over to the center. Make sure the edges are sealed and that there are no air pockets. Bring back a small corner (figure 14-28C).



FIGURE 14-27B Fold back one corner on the top fold of the linen.

PROCEDURE 14:5A



FIGURE 14-28A Place the instrument in the center of the wrap. Fold the bottom corner in to the center.

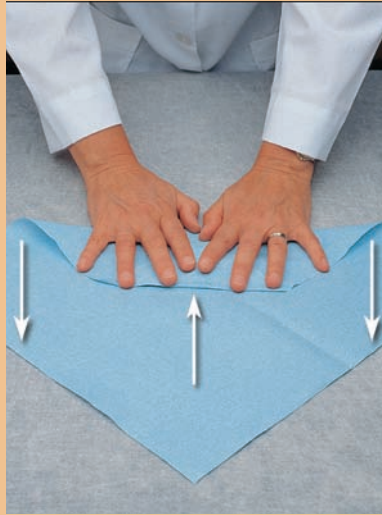

FIGURE 14-28B Turn a small corner back to form a tab.



FIGURE 14-28C Fold in one side and fold back a tab.



FIGURE 14-28D Fold in the opposite side and fold back a tab.

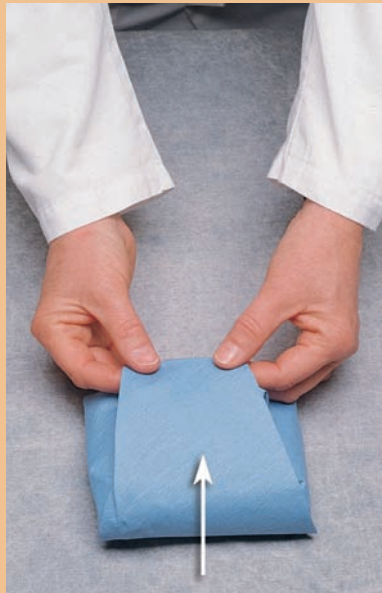



FIGURE 14-28E Bring the final corner up and over the top of the pack and tuck it in, leaving a small corner exposed.



FIGURE 14-28F Secure the package with autoclave tape. Label it with the date, contents, and your initials.

PROCEDURE 14:5A

 **CAUTION:** Any open areas at corners will allow pathogens to enter.

9. Fold in the other side corner. Again, watch for and avoid open edges. Bring back a small corner (figure 14-28D).
10. Bring the final corner up and over the top of the package. Check the two edges to be sure they are sealed and tight. Tuck this under the pocket created by the previous folds. Leave a small corner exposed so it can be used when unwrapping the package (figure 14-28E).

NOTE: This is frequently called an “envelope” wrap, because the final corner is tucked into the wrap similar to the way the flap is tucked into an envelope.

11. Secure with autoclave or pressure-sensitive indicator tape.

NOTE: If regular masking tape is used, attach an autoclave indicator to reflect when contents are sterilized.

12. Label the package by marking the tape with the date and contents (figure 14-28F). Some health care agencies may require you to initial the label.

NOTE: For certain items, the type or size of item should be noted, for example, curved hemostat or mosquito hemostat, hand towel or bath towel, small bowl or large bowl.

NOTE: Contents will not be sterile after 30 days, so the date of sterilization must be noted on the package.

13. Check the package. It should be firm enough for handling but loose enough for proper circulation of steam.

14. To use a plastic or paper autoclave bag (refer to figure 14-23), select or cut the correct size for the item to be sterilized. Place the clean item inside the bag. Double fold the open end(s) and tape or secure with autoclave tape. Check the package to make sure it is secure.

NOTE: In some agencies, the ends are sealed with heat prior to autoclaving.

NOTE: If the bag has an autoclave indicator, regular masking tape can be used to seal the ends.

15. Replace all equipment used.
16. Wash hands.

Practice

Go to the workbook and use the evaluation sheet for 14:5A, Wrapping Items for Autoclaving, to practice this procedure. When you believe you have mastered this skill, sign the sheet and give it to your instructor for further action.



Final Checkpoint Using the criteria listed on the evaluation sheet, your instructor will grade your performance.

PROCEDURE 14:5B

Loading and Operating an Autoclave

NOTE: Follow the operating instructions for your autoclave. The basic principles of loading apply to all autoclaves. Basic controls for one autoclave are shown in figure 14-29.

Equipment and Supplies

Autoclave, distilled water, small pitcher or measuring cup, items wrapped or prepared for autoclaving, time chart for autoclave, 14:5 Information section

Procedure

Review the Information section for 14:5, Sterilizing with an Autoclave. Then proceed with the following activities. You should read through the procedure first, checking against the diagram. Then practice with an autoclave.

1. Assemble equipment.
2. Wash and dry hands thoroughly.
3. Check the three-prong plug and the electrical cord. If either is damaged or prongs are missing, do not use the autoclave. If no problems are present, plug the cord into a wall outlet.
4. Use distilled water to fill the reservoir to within 2 1/2 inches below the opening



FIGURE 14-29 Autoclave control valves vary, but most contain the same basic controls.

or to the level indicated on the autoclave.

NOTE: Distilled water prevents the collection of mineral deposits and prolongs the life and effectiveness of the autoclave.

5. Check the pressure gauge to make sure it is at zero.

CAUTION: Never open the door unless the pressure is zero.

6. Open the safety door by following the manufacturer's instructions. Some door handles require an upward and inward pressure; others require a side-pressure technique.

7. Load the autoclave. Make sure all articles have been prepared correctly. Check for autoclave indicators, secure wraps, and correct labels. Separate loads so all items require the same time, temperature, and pressure. Place packages on their sides. Place bowls or basins on their sides so air and steam can flow in and out of the container (figure 14-30). Make sure there is space between the packages so the steam can circulate.

NOTE: Check to make sure no large packages block the steam flow to smaller packages. Place large packages on the bottom.

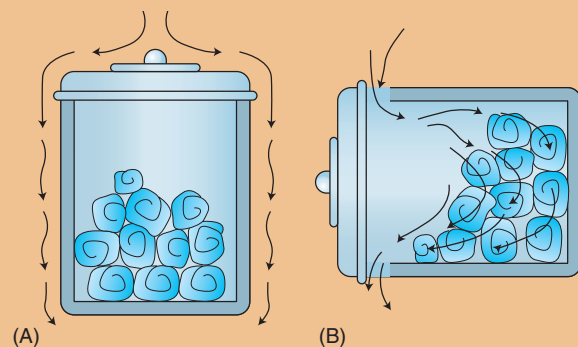





FIGURE 14-30 Bowls or basins should be placed on their sides in the autoclave so air and steam can flow in and out of the container: (A) incorrect placement; (B) correct placement.

PROCEDURE 14:5B

-  **CAUTION:** Make sure no item comes in contact with the sides, top, or door of the autoclave chamber.
8. Follow the instructions for filling the chamber with the correct amount of water. Most autoclaves have a “Fill” setting on the control. Allow water to enter the chamber until the water covers the fill plate inside the chamber.
 9. When the correct amount of water is in the chamber, follow the instructions for stopping the flow of water. In many autoclaves, turning the control valve to “Sterilize” stops the flow of water from the reservoir.
 10. Check the load in the chamber to be sure it is properly spaced. The chamber can also be loaded at this point, if this has not been done previously.
 11. Close and lock the door.
-  **CAUTION:** Be sure the door is securely locked; check by pulling slightly.
12. Read the time chart for the specific time and temperature required for sterilization of items that were placed in the autoclave.
 13. After referring to the chart provided with the autoclave or reviewing figure 14-25, set the control valves to allow the temperature and pressure to increase in the autoclave.
 14. When the desired temperature (usually 250–254°F or 121–123°C) and pressure (usually 15 pounds) have been reached, set the controls to maintain the desired temperature during the sterilization process. Follow the manufacturer’s instructions.
 15. Based on the information in the time chart, set the timer to the correct time.

NOTE: Many autoclaves require you to rotate the timer past 10 (minutes) before setting the time.
 16. Check the pressure and temperature gauges at intervals to make sure they remain as originally set.

NOTE: Most autoclaves automatically shut off when pressure reaches 35 pounds.
 17. When the required time has passed, set the controls so the autoclave will vent the steam from the chamber.
 18. Put on safety glasses.

 **CAUTION:** Never open the door without glasses. The escaping steam can burn the eyes.
 19. Check the pressure and temperature gauges. When the pressure gauge is at zero, and the temperature gauge is at or below 212°F, open the door about 1/2 to 1 inch to permit thorough drying of contents.

 **CAUTION:** Do not open the door until pressure is zero.

NOTE: Most autoclaves have a safety lock on the door that does not release until the pressure is at zero.
 20. After the autoclaved items are completely dry, remove and store them in a dry, dust-free area.

 **CAUTION:** Handle supplies and equipment carefully. They may be hot.
 21. If there are additional loads to run, leave the main valve in the vent position. This will keep the autoclave ready for immediate use.
 22. If this is the final load, turn the autoclave off. Unplug the cord from the wall outlet; do not pull on the cord.

NOTE: The autoclave must be cleaned on a regular basis. Follow manufacturer’s instructions.
 23. Replace all equipment used.
 24. Wash hands.

Practice

Go to the workbook and use the evaluation sheet for 14:5B, Loading and Operating an Autoclave, to practice this procedure. When you believe you have mastered this skill, sign the sheet and give it to your instructor for further action.



Final Checkpoint Using the criteria listed on the evaluation sheet, your instructor will grade your performance.

14:6 Information



Using Chemicals for Disinfection

Many health fields require the use of chemicals for aseptic control. Certain points that must be observed while using the chemicals are discussed in the following section.

Chemicals are frequently used for aseptic control. Many chemicals do not kill spores and viruses; therefore, chemicals are not a method of sterilization. Because sterilization does not occur, **chemical disinfection** is the appropriate term (rather than cold sterilization, a term sometimes used). A few chemicals will kill spores and viruses, but these chemicals frequently require that instruments be submerged in the chemical for 10 or more hours. It is essential to read an entire label to determine the effectiveness of the product before using any chemical.

Chemicals are used to disinfect instruments that do not penetrate body tissue. Many dental instruments, percussion hammers, scissors, and similar items are examples. In addition, chemicals are used to disinfect thermometers and other items that would be destroyed by the high heat used in the autoclave.

Proper cleaning of all instruments or articles is essential. Particles or debris on items may contaminate the chemicals and reduce their effectiveness. In addition, all items must be rinsed thoroughly because the presence of soap can also reduce the effectiveness of chemicals. The articles must be dry before being placed in the disinfectant to keep the chemical at its most effective strength.

Some chemical solutions used as disinfectants are 90-percent isopropyl alcohol, formaldehyde-alcohol, 2-percent phenolic germicide, 10-percent bleach (sodium hypochlorite) solution, glutaraldehyde, iodophor, Lysol, Cidex, and benzalkonium (zephiran). The manufacturer's directions should be read completely before using any solution. Some solutions must be diluted or mixed before use. The directions will

also specify the recommended time for the most thorough disinfection.

Chemical solutions can cause rust to form on certain instruments, so antirust tablets or solutions are frequently added to the chemicals. Again, it is important to read the directions provided with the tablets or solution. If improperly used, antirust substances may cause a chemical reaction with a solution and reduce the effectiveness of the chemical disinfectant.

The container used for chemical disinfection must be large enough to accommodate the items. In addition, the items should be separate so each one will come in contact with the chemical. A tight-fitting lid must be placed on the container while the articles are in the solution to prevent evaporation that could affect the strength of the solution. The lid also decreases the chance of dust and airborne particles from falling into the solution.

The chemical disinfectant must completely cover the article. This is the only way to be sure that all parts of the article will be disinfected.

Before removing items from solutions, health workers must wash their hands. Sterile gloves or sterile pick-ups or transfer forceps may be used to remove the instruments from the solution. The items should be rinsed with sterile water to remove any remaining chemical solution. After rinsing, the instruments are placed on a sterile or clean towel to dry, and then stored in a drawer or dust-free closet.

Solutions must be changed frequently. Some solutions can be used over a period of time, but others must be discarded after one use. Follow the manufacturer's instructions. However, any time contamination occurs or dirt is present in the solution, discard it. A fresh solution must be used.

STUDENT: *Go to the Workbook and complete the assignment sheet for 14:6, Using Chemicals for Disinfection. Then return and continue with the procedure.*

PROCEDURE 14:6

Using Chemicals for Disinfection

Equipment and Supplies

Chemicals, container with tight-fitting lid, basin, soap, water, instruments, brush, sterile pick-ups or transfer forceps, sterile towel, sterile gloves, eye protection, disposable gloves

Procedure

1. Assemble equipment.
2. Wash hands. Put on disposable or heavy-duty utility gloves and eye protection.

NOTE: Wear gloves if any of the instruments or equipment are contaminated with blood or body fluids. Wear eye protection if there is any chance splashing will occur.

3. Wash all instruments or equipment thoroughly. Use warm soapy water. Use the brush on serrated edges of instruments.

NOTE: All tissue and debris must be removed from the instrument or item or it will not be disinfected.

4. Rinse in cool water to remove soapy residue. Then rinse well with hot water. Dry all instruments or equipment thoroughly.

NOTE: Water on the instruments or equipment will dilute the chemical disinfectant.

5. Check container. Make sure lid fits securely.

NOTE: A loose cover will permit entrance of pathogens and/or evaporation of the chemical solution.

6. Place instruments in the container. Make sure there is a space between instruments. Leave hinged edges open

so the solution can flow between the surfaces.

7. Carefully read label instructions about the chemical solution. Some solutions must be diluted. Check the manufacturer's recommended soaking time.

CAUTION: Reread instructions to be sure solution is safe to use on instruments.

NOTE: An antirust substance must be added to some solutions.

8. Pour solution into the container slowly to avoid splashing. Make sure that all instruments are covered (figure 14-31). Close the lid of the container.

NOTE: Read label three times: before pouring, while pouring, and after pouring.

CAUTION: Avoid splashing the chemical on your skin. Improper handling of chemicals may cause burns and/or injuries.

9. Remove gloves. Wash hands.

10. Leave the instruments in the solution for the length of time recommended by the manufacturer.



FIGURE 14-31 Pour the chemical disinfectant into the container until all instruments are covered with solution.

PROCEDURE 14:6

NOTE: Twenty to 30 minutes is the usual soaking time.

NOTE: If the solution requires a long period (for example, 10–12 hours) for disinfecting, label the container with the date and time the process began, ending date and time, and your initials.

11. When instruments have soaked the correct amount of time, use sterile gloves or sterile pick-ups or transfer forceps to remove the instruments from the solution. Hold the instruments over a sink or basin and pour sterile water over them to rinse them thoroughly. Place them on a sterile towel to dry. A second sterile towel is sometimes used to dry the instruments or to cover the instruments while they are drying. Store the instruments in special drawers, containers, or dust-free closets.

NOTE: Some contamination occurs when instruments are exposed to the air. In some cases, such as with external instruments, this minimal contamination will not affect usage.

12. Replace all equipment used.



CAUTION: If the disinfectant solution can be used again, label the container with the name of the disinfectant, date, and number of days it can be used according to manufacturer's instructions. When solutions cannot be reused, dispose of the solution according to manufacturer's instructions.

13. Remove gloves. Wash hands.

Practice

Go to the workbook and use the evaluation sheet for 14:6, Using Chemicals for Disinfection, to practice this procedure. When you believe you have mastered this skill, sign the sheet and give it to your instructor for further action.



Final Checkpoint Using the criteria listed on the evaluation sheet, your instructor will grade your performance.

14:7 Information



Cleaning with an Ultrasonic Unit

Ultrasonic units are used in many dental and medical offices and other health agencies to remove dirt, debris, blood, saliva, and tissue from a large variety of instruments prior to sterilizing them. **Ultrasonic** cleaning uses sound waves to clean. When the ultrasonic unit is turned on, the sound waves produce millions of microscopic bubbles in a cleaning solution. When the bubbles strike the items being cleaned, they explode, a process known as **cavitation**, and drive the cleaning solution onto the article. Accumulated dirt and residue are easily and gently removed from the article.

Ultrasonic cleaning is not sterilization because spores and viruses remain on the arti-

cles. If sterilization is desired, other methods must be used after the ultrasonic cleaning.

Only ultrasonic solutions should be used in the unit. Different solutions are available for different materials. A general, all-purpose cleaning solution is usually used in the permanent tank and to clean many items. There are other specific solutions for alginate, plaster and stone removal, and tartar removal. The solution chart provided with the ultrasonic unit will state which solution should be used. It is important to read labels carefully before using any solutions. Some solutions must be diluted before use. Some can be used only on specific materials. All solutions are toxic. They can also cause skin irritation, so contact with the skin and eyes should be avoided. Solutions should be discarded when they become cloudy or contaminated, or if cleaning results are poor.

The permanent tank of the ultrasonic unit (figure 14-32) must contain a solution at all times. A general, all-purpose cleaning solution is used most of the time. Glass beakers or auxiliary pans or baskets can then be placed in the permanent tank. The items to be cleaned and the proper cleaning solution are then put in the beakers or pans. The bottoms of the beakers or pans must always be positioned below the level of the solution present in the permanent tank. In this way, cavitation can be transmitted from the main tank and through the solution to the items being cleaned in the beakers or pans. The ultrasonic unit should never be operated without solutions in both containers. In addition, the items being cleaned must be submerged in the cleaning solution.

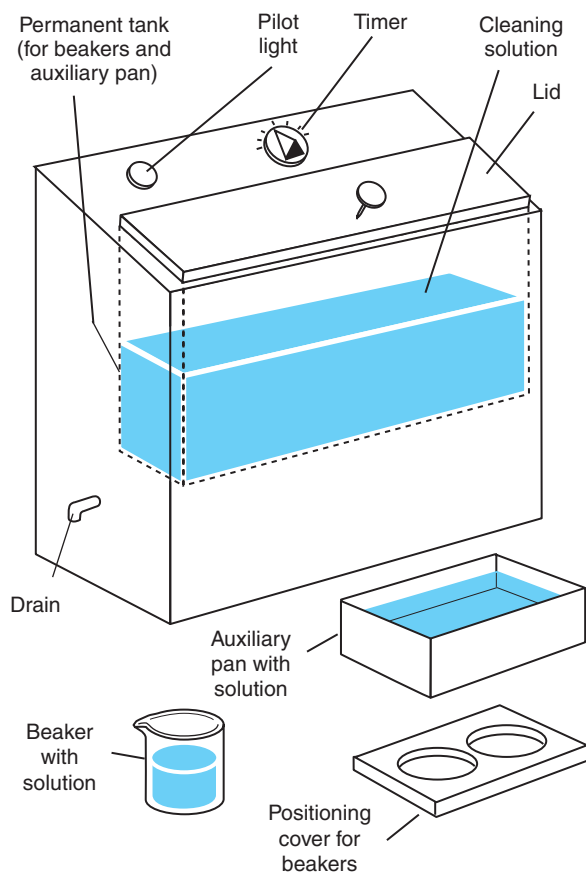

FIGURE 14-32 Parts of an ultrasonic cleaning unit.

Many different items can be cleaned in an ultrasonic unit. Examples include instruments, impression trays, glass products, and most jewelry. The ultrasonic unit should not be used on jewelry with pearls or pasted stones. The sound waves can destroy the pearls or the paste holding the stones. Prior to cleaning, most of the dirt or particles should be brushed off the items being cleaned. It is better to clean a few articles at a time and avoid overloading the unit. If items are close together, the process of cavitation is poor because the bubbles cannot strike all parts of the items being cleaned.

The glass beakers used in the ultrasonic unit are made of a type of glass that allows the passage of sound waves. After continual use, the sound waves etch the bottom of the beakers. A white, opaque coating forms. The beakers must be discarded and replaced when this occurs. After each use, the beakers should be washed with soap and water and rinsed thoroughly to remove any soapy residue. They must be dry before being filled with solution because water in the beaker can dilute the solution.

The permanent tank of the unit must be drained and cleaned at intervals based on tank use or appearance of the solution in the tank. A drain valve on the side of the tank is opened to allow the solution to drain. The tank is then wiped with a damp cloth or disinfectant. Another damp cloth or disinfectant is used to wipe off the outside of the unit. The unit should never be submerged in water to clean it. After cleaning, a fresh solution should be placed in the permanent tank.

The manufacturer's instructions must be read carefully before using any ultrasonic unit. Most manufacturers provide cleaning charts that state the type of solution and time required for a variety of cleaning problems. Each time an item is cleaned in an ultrasonic unit, the chart should be used to determine the correct cleaning solution and time required.

STUDENT: Go to the workbook and complete the assignment sheet for 14:7, *Cleaning with an Ultrasonic Unit*. Then return and continue with the procedure.

PROCEDURE 14:7

Cleaning with an Ultrasonic Unit

Equipment and Supplies

Ultrasonic unit, permanent tank with solution, beakers, auxiliary pan or basket with covers, beaker bands, cleaning solutions, transfer forceps or pick-ups, paper towels, gloves, brush, soap, water for rinsing, articles for cleaning, solution chart

Procedure

1. Assemble all equipment.
2.  Wash hands. Put on gloves if any items are contaminated with blood, body fluids, secretions, or excretions.

NOTE: Use heavy-duty utility gloves if instruments are sharp.

3. Use a brush and soap and water to remove any large particles of dirt from articles to be cleaned. Rinse articles thoroughly. Dry items.

NOTE: Rinsing is important because soap may interact with the cleaning solution.



FIGURE 14-33A The auxiliary basket can be used to clean larger items in an ultrasonic unit.

4. Check the permanent tank to be sure it has enough cleaning solution. An all-purpose cleaning solution is usually used in this tank.

 **CAUTION:** Never run the unit without solution in the permanent tank.

NOTE: Many solutions must be diluted before use; if new solution is needed, read the instructions on the bottle.

5. Pour the proper cleaning solution into the auxiliary pan or beakers.

NOTE: Use the cleaning chart to determine which solution to use.

 **CAUTION:** Read label before using.

 **CAUTION:** Handle solutions carefully. Avoid contact with skin and eyes.

6. Place the beakers, basket, or auxiliary pan into the permanent tank (figures 14-33A and B). Use beaker positioning covers and beaker bands. Beaker bands are large bands that circle the beakers to hold them in position and keep them from hitting the bottom of the permanent tank.



FIGURE 14-33B Glass beakers can be used to clean smaller items in an ultrasonic unit.

PROCEDURE 14:7

7. Check to be sure that the bottoms of the beakers, basket, or pan are below the level of solution in the permanent tank.

NOTE: For sonic waves to flow through solutions in the beakers, basket, or pan, the two solution levels must overlap.

8. Place articles to be cleaned in the beakers, basket, or pan. Be sure the solution completely covers the articles. Do not get solution on your hands.

NOTE: Remember that pearls or pasted stones cannot be cleaned in an ultrasonic unit.

9. Turn the timer past 5 (minutes) and then set the proper cleaning time. Use the cleaning chart to determine the correct amount of time required for the items. Most articles are cleaned in 2–5 minutes.
10. Check that the unit is working. You should see a series of bubbles in both solutions. This is called *cavitation*.

 **CAUTION:** Do not get too close. Solution can spray into your face and eyes. Use beaker lids to prevent spray.

11. When the timer stops, cleaning is complete. Use transfer forceps or pick-ups to lift articles from the basket, pan, or beakers. Place the articles on paper towels. Then rinse articles thoroughly under running water.

 **CAUTION:** Avoid contact with skin. Solutions are toxic.

12. Allow articles to air-dry or dry them with paper towels. Inspect the articles for cleanliness. If they are not clean, repeat the process.

13. Periodically change solutions in the permanent tank and auxiliary containers. Do this when solutions become cloudy or cleaning has not been effective. To clean the permanent tank, place a container under the side drain to collect the solution. Then open the valve and drain solution from the tank. Wash the inside with a damp cloth or disinfectant. To clean the auxiliary pans or beakers, discard the solution. (It can be poured down the sink, but allow water to run for a time after disposing of the solution.) Then wash the containers and rinse thoroughly.

NOTE: If the bottoms of beakers are etched and white, the beakers must be discarded and replaced.

14. Clean and replace all equipment used. Make sure all beakers are covered with lids.
15. Wash hands.

Practice

Go to the workbook and use the evaluation sheet for 14:7, Cleaning with an Ultrasonic Unit, to practice this procedure. When you believe you have mastered this skill, sign the sheet and give it to your instructor for further action.

 **Final Checkpoint** Using the criteria listed on the evaluation sheet, your instructor will grade your performance.

14:8 INFORMATION



Using Sterile Techniques

Many procedures require the use of sterile techniques to protect the patient from further infection. *Surgical asepsis* refers to procedures that keep an object or area free from living organisms. The main facts are presented here.

Sterile means “free from all organisms,” including spores and viruses. **Contaminated** means that organisms and pathogens are present. While working with sterile supplies, it is important that correct techniques be followed to maintain sterility and avoid contamination. It is also important that you are able to recognize sterile surfaces and contaminated surfaces.

A clean, uncluttered working area is required when working with sterile supplies. A sterile object must never touch a nonsterile object. If other objects are in the way, it is easy to contaminate sterile articles. If sterile articles touch the skin or any part of your clothing, they are no longer sterile. Because any area below the waist is considered contaminated, sterile articles must be held away from and in front of the body and above the waist.

Once a **sterile field** has been set up (for example, a sterile towel has been placed on a tray), never reach across the top of the field. Microorganisms can drop from your arm or clothing and contaminate the field. Always reach in from either side to place additional articles on the field. Keep the sterile field in constant view. Never turn your back to a sterile field. Avoid coughing, sneezing, or talking over the sterile field because airborne particles can fall on the field and contaminate it.

The 2-inch border around the sterile field (towel-covered tray) is considered contaminated. Therefore, 2 inches around the outside of the field must not be used when sterile articles are placed on the sterile field.

All sterile items must be checked carefully before they are used. If the item was autoclaved and dated, most health care facilities believe the date should not be more than 30 days from autoclaving. Follow agency guidelines for time limits. If tears or stains are present on the package, the item should *not* be used because it could be contaminated. If there are any signs of moisture on the package, it has been contaminated and should *not* be used.

Organisms and pathogens travel quickly through a wet surface, so the sterile field must be kept dry. If a sterile towel or article gets wet, contamination has occurred. It is very important to use care when pouring solutions into sterile bowls or using solutions around a sterile field.

Various techniques can be used to remove articles from sterile wraps, depending on the article being unwrapped. Some common techniques are the drop, mitten, and transfer-forceps techniques:

- ◆ *Drop technique:* This technique is used for gauze pads, dressings, and small items. The wrapper is partially opened and then held upside down over the sterile field. The item drops out of the wrapper and onto the sterile field (figure 14-34A). It is important to keep fingers back so the article does not touch the skin as it falls out of the wrapper. It is also important to avoid touching the inside of the wrapper.
- ◆ *Mitten technique:* This technique is used for bowls, drapes, linen, and other similar items. The wrapper is opened and its loose ends are grasped around the wrist with the opposite hand (figure 14-34B). In this way, a mitten is formed around the hand that is still holding the item (for example, a bowl). With the mitten hand, the item can be placed on the sterile tray.
- ◆ *Transfer forceps:* These are used for cotton balls, small items, or articles that cannot be removed by the drop or mitten techniques. Either sterile gloves or sterile transfer forceps (pick-ups) are used. Sterile transfer forceps or pick-ups are removed from their container of disinfectant solution and used to grasp the



FIGURE 14-34A Sterile items can be dropped from the wrapper onto the sterile field.



FIGURE 14-34B By using the wrap as a mitten, sterile supplies can be placed on a sterile field.

article from the opened package. The item is removed from the opened, sterile wrap and placed on the sterile field (figure 14-34C). The transfer forceps must be pointed in a downward direction. If they are pointed upward, the solution will flow back to the handle, become contaminated, and return to contaminate the sterile tips when they are being used to pick up items. In addition, care must be taken not to touch the sides or rim of the forceps container while removing or inserting the transfer forceps. Also, the transfer forceps must be shaken gently to get rid of excess disinfectant solution before they are used.

Make sure the sterile tray is open and you are ready to do the sterile procedure *before* putting the sterile gloves on your hands. Sterile gloves are considered sterile on the outside and contaminated on the inside (side against the skin). Once they have been placed on the hands, it is impor-



FIGURE 14-34C Sterile transfer forceps or pick-ups can be used to grasp sterile items and place them on a sterile field.

tant to hold the hands away from the body and above the waist to avoid contamination. Handle only sterile objects while wearing sterile gloves.

If at any time during a procedure there is any suspicion that you have contaminated any article, start over. Never take a chance on using contaminated equipment or supplies.

A wide variety of commercially prepared sterile supplies is available. Packaged units are often set up for special procedures, such as changing dressings. Many agencies use these units instead of setting up special trays. Observe all sterile principles while using these units and read any directions provided with the units.

STUDENT: Go to the workbook and complete the assignment sheet for 14:8, *Using Sterile Techniques*. Then return and continue with the procedures.

PROCEDURE 14:8A

Opening Sterile Packages

Equipment and Supplies

Sterile package of equipment or supplies, a table or other flat surface, sterile field (tray with sterile towel)

Procedure

1. Assemble equipment.
2. Wash hands.
3. Take equipment to the area where it will be used. Check the autoclave indicator and date on the package. Check the package for stains, tears, moisture, or

PROCEDURE 14:8A

evidence of contamination. Do *not* use the package if there is any evidence of contamination.

NOTE: Contents are not considered sterile if 30 days have elapsed since autoclaving.

4. Pick up the package with the tab or sealed edge pointing toward you. If the item is small, it can be held in the hand while being unwrapped. If it is large, place it on a table or other flat surface.
5. Loosen the wrapper fastener (usually tape).
6. Check to be sure the package is away from your body. If it is on a table, make sure it is not close to other objects.

NOTE: Avoid possible contamination by keeping sterile supplies away from other objects.

7. Open the distal (furthest) flap of the wrapper by grasping the outside of the wrapper and pulling it away from you (figure 14-35A).

CAUTION: Do not reach across the top of the package. Reach around the package to open it.



FIGURE 14-35A To open a sterile package, open the top flap away from you, handling only the outside of the wrap.

8. With one hand, raise a side flap and pull laterally (sideways) away from the package (figure 14-35B).

CAUTION: Do not touch the inside of the wrapper at any time.

9. With the opposite hand, open the other side flap by pulling the tab to the side (figure 14-35C).

NOTE: Always reach in from the side. Never reach across the top of the sterile field or across any opened edges.

10. Open the proximal (closest) flap by lifting the flap up and toward you. Then drop it over the front of your hand (or the table) (figure 14-35D).

CAUTION: Be careful not to touch the inside of the package or the contents of the package.

11. Transfer the contents of the sterile package using one of the following techniques:

- a. *Drop:* Separate the ends of the wrap and pull apart gently (figure 14-36). Avoid touching the inside of the wrap. Secure the loose ends of the wrap and hold the package upside down over



FIGURE 14-35B Open one side by pulling the wrap out to the side.

PROCEDURE 14:8A



FIGURE 14-35C Open the opposite side by pulling the wrap out to the opposite side.

the sterile field. Allow the contents to drop onto the sterile tray (refer to figure 14-34A).

- b. *Mitten*: Grasp the contents securely by holding on to the outside of the wrapper as you unwrap it. With your free hand, gather the loose edges of the wrapper together and hold them



FIGURE 14-36 Separate the ends of the wrap and pull the edges apart gently without touching the contents.



FIGURE 14-35D Open the side nearest to you by pulling back on the wrap.

securely around your wrist. This can be compared to making a mitten of the wrapper (with the sterile equipment on the outside of the mitten). Place the item on the sterile tray or hand it to someone who is wearing sterile gloves (refer to figure 14-34B).

- c. *Transfer forceps*: Remove forceps from their sterile container, taking care not to touch the side or rim of the container with the forceps (figure 14-37). Hold the forceps pointed downward. Shake them gently to remove excess disinfectant solution. Take care not to touch anything with the forceps. Use the forceps to grasp the item in the package and then place the item on the sterile tray.

NOTE: The method of transfer depends on the sterile item being transferred.

NOTE: If at any time during the procedure there is any suspicion that you have contaminated any article, start over. Never take a chance on using equipment for a sterile procedure if there is any possibility that the equipment is contaminated.

12. Replace all equipment used.
13. Wash hands.

PROCEDURE 14:8A



FIGURE 14-37 Remove the transfer or pick-up forceps without touching the sides or rim of the container and point them in a downward direction.

Practice

Go to the workbook and use the evaluation sheet for 14:8A, *Opening Sterile Packages*, to practice this procedure. When you believe you have mastered this skill, sign the sheet and give it to your instructor for further action.



Final Checkpoint Using the criteria listed on the evaluation sheet, your instructor will grade your performance.

PROCEDURE 14:8B

Preparing a Sterile Dressing Tray

Equipment and Supplies

Tray or Mayo stand, sterile towels, sterile basin, sterile cotton balls or gauze sponges, sterile dressings (different sizes), antiseptic solution, forceps in disinfectant solution

Procedure

1. Assemble all equipment.
2. Wash hands.

3. Check the date and autoclave indicator for sterility. If more than 30 days have elapsed, use another package with a more recent date. Put the unsterile package aside for resterilization. Check the package for stains, tears, moisture, or evidence of contamination. Do not use the package if there is any evidence of contamination.
4. Place the tray on a flat surface or a Mayo stand.

NOTE: Make sure the work area is clean and dry, and there is sufficient room to work.

PROCEDURE 14:8B

- Open the package that contains the sterile towel. Be sure it is held away from your body. Place the wrapper on a surface away from the tray or work area. Touch only the outside of the towel. Pick up the towel at its outer edge. Allow it to open by releasing the fanfolds (figure 14-38A). Place the towel with the outer side (side you have touched) on the tray or Mayo stand (figure 14-38B). The untouched, or sterile, side will be facing



FIGURE 14-38A Pick up the sterile towel at its outer edge and allow it to open by releasing the fanfolds.



FIGURE 14-38B Place the towel on the Mayo stand without reaching across the top of the towel.

up to create a sterile field. Holding on to the outside edges of the towel, fanfold the back of the towel so the towel can be used later to cover the supplies.

CAUTION: Do not reach across the top of the sterile field. Reach in from either side.

NOTE: If you are setting up a relatively large work area, one towel may not be large enough when fanfolded to cover the supplies. In such a case, you will need a second sterile towel (later) to cover your sterile field.

CAUTION: At all times, make sure that you do *not* touch the sterile side of the towel. Avoid letting the towel come in contact with your uniform, other objects, or contaminated areas.

- Correctly unwrap the package containing the sterile basin. Place the basin on the sterile field. Do not place it close to the edge.

NOTE: A 2-inch border around the outside edges of the sterile field is considered to be contaminated. No equipment should come in contact with this border.

CAUTION: Make sure that the wrapper does *not* touch the towel while placing the basin in position.

- Unwrap the package containing the sterile cotton balls or gauze sponges. Use a dropping motion to place them in the basin. Do not touch the basin with the wrapper.
- Unwrap the package containing the larger dressing. Use the sterile forceps to remove the dressing from the package and place it on the sterile field. Make sure the dressing is not too close to the edge of the sterile field.

NOTE: The larger, outside dressing is placed on the sterile field first (before other dressings). In this way, the supplies will be in the order of use. For

PROCEDURE 14:8B

example, gauze dressings placed directly on the skin will be on top of the pile, and a thick abdominal pad used on top of the gauze pads will be on the bottom of the pile.

NOTE: The forceps must be lifted straight up out of the container and must *not* touch the side or rim of the container. Keep the tips pointed down and above the waist at all times. Shake off excess disinfectant solution.

9. Unwrap the inner dressings correctly. Use the sterile forceps to place them on top of the other dressings on the sterile field, or use a drop technique.

NOTE: Dressings are now in a pile; the dressing that will be used first is on the top of the pile.

NOTE: The number and type of dressings needed is determined by checking the patient being treated.

10. Open the bottle containing the correct antiseptic solution. Place the cap on the table, with the inside of the cap facing up. Pour a small amount of the solution into the sink to clean the lip of the bottle. Then hold the bottle over the basin and pour a sufficient amount of solution into the basin (figure 14-39).

 **CAUTION:** Make sure that no part of the bottle touches the basin or the sterile field. Pour carefully to avoid splashing. If the sterile field gets wet, the entire tray will be contaminated, and you must begin again.

11. Check the tray to make sure all needed equipment is on it.

12. Pick up the fanfolded edge of the towel by placing one hand on each side edge of the towel on the underside, or contaminated side. Do not touch the sterile side. Keep your hands and arms to the side of the tray, and bring the towel forward to cover the supplies.



FIGURE 14-39 Avoid splashing the solution onto the sterile field while pouring it into the basin.

NOTE: A second sterile towel may be used to cover the supplies if the sterile field area is too large to be covered by the one fanfolded towel (figure 14-40).

 **CAUTION:** Never reach across the top of the sterile tray.



FIGURE 14-40 Use a second sterile towel to cover the sterile towel to cover the sterile field, taking care not to reach across the field.

PROCEDURE 14:8B

13. Once the sterile tray is ready, never allow it out of your sight. Take it to the patient area and use it immediately. If you need more equipment, you must take the tray with you. This is the only way to be completely positive that the tray does not become contaminated.
14. Replace equipment.
15. Wash hands.

Practice

Go to the workbook and use the evaluation sheet for 14:8B, *Preparing a Sterile Dressing Tray*, to practice this procedure. When you believe you have mastered this skill, sign the sheet and give it to your instructor for further action.



Final Checkpoint Using the criteria listed on the evaluation sheet, your instructor will grade your performance.

PROCEDURE 14:8C

Donning and Removing Sterile Gloves

Equipment and Supplies

Sterile gloves

Procedure

1. Assemble equipment and take it to the area where it is to be used. Check the package for stains, tears, moisture, or evidence of contamination. Do *not* use the package if there is any evidence of contamination.
2. Remove rings. Wash hands. Dry hands thoroughly.
3. Open the package of gloves, taking care not to touch the inside of the inner wrapper. The inner wrapper contains the gloves. Reach in from the sides to open the inner package and expose the sterile gloves (figure 14-41A). The folded cuffs will be nearest you.



CAUTION: If you touch the *inside* of the package (where the gloves are), get a new package and start again.

4. The glove for the right hand will be on the right side and the glove for the left hand will be on the left side of the package. With the thumb and forefinger of the nondominant hand, pick up the top edge of the folded-down cuff (inside of glove) of the glove for the dominant hand. Remove the glove carefully (figure 14-41B).



CAUTION: Do *not* touch the outside of the glove. This is sterile. Only the part that will be next to the skin can be touched. Remember, unsterile touches unsterile and sterile touches sterile.

5. Hold the glove by the inside cuff and slip the fingers and thumb of your other hand into the glove. Pull it on carefully (figure 14-41C).

NOTE: Hold the glove away from the body. Pull gently to avoid tearing the glove.

PROCEDURE 14:8C

6. Insert your gloved hand under the cuff (outside) of the other glove and lift the glove from the package (figure 14-41D). Do not touch any other area with your gloved hand while removing the glove from the package.

CAUTION: If contamination occurs, discard the gloves and start again.

7. Holding your gloved hand under the cuff of the glove, insert your other hand into the glove (figure 14-41E). Keep the thumb of your gloved hand tucked in to avoid possible contamination.

8. Turn the cuffs up by manipulating only the sterile surface of the gloves (sterile touches sterile). Go up under the folded cuffs, pull out slightly, and turn cuffs over and up (figure 14-41F). Do not touch the inside of the gloves or the skin with your gloved hand.

9. Interlace the fingers to position the gloves correctly, taking care not to touch the skin with the gloved hands (figure 14-41G).

CAUTION: If contamination occurs, start again with a new pair of gloves.

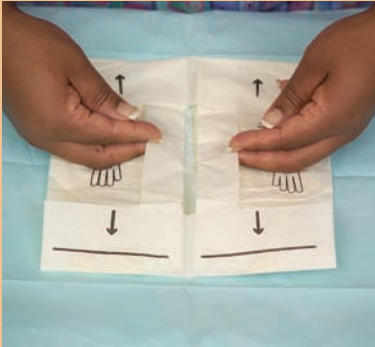

FIGURE 14-41A Reach in from the sides to open the inner package and expose the sterile gloves.



FIGURE 14-41B Pick up the first glove by grasping the glove on the top edge of the folded-down cuff.



FIGURE 14-41C Hold the glove securely by the cuff and slip the opposite hand into the glove.



FIGURE 14-41D Slip the gloved fingers under the cuff of the second glove to lift it from the package.



FIGURE 14-41E Hold the gloved hand under the cuff while inserting the other hand into the glove.



FIGURE 14-41F Insert the gloved fingers under the cuff, pull out slightly, and turn the cuffs over and up without touching the inside of the gloves or the skin.

PROCEDURE 14:8C



FIGURE 14-41G Interlace the fingers to position the gloves correctly, taking care not to touch the skin with the gloved hands.

10. Do not touch anything that is not sterile once the gloves are in place. Gloves are applied for the purpose of performing procedures requiring sterile technique. During the procedure, they will become contaminated with organisms related to the patient's condition, for example, wound drainage, blood, or other body discharges. Even a clean, dry wound may contaminate gloves.

NOTE: Gloved hands should remain in position above the waist. Do *not* allow them to fall below waist.

11. After the procedure requiring sterile gloves is completed, dispose of all contaminated supplies before removing gloves.

NOTE: This reduces the danger of cross-infection caused by handling contaminated supplies without glove protection.

12. To remove the gloves, use one gloved hand to grasp the other glove by the outside of the cuff. Taking care not to touch the skin, remove the glove by pulling it down over the hand. It will be wrong side out when removed.

NOTE: This prevents contamination of your hands by organisms picked up dur-

ing performance of the procedure. Now you must consider the outside of the gloves contaminated, and the area inside, next to your skin, clean.

13. Insert your bare fingers on the inside of the second glove. Remove the glove by pulling it down gently, taking care not to touch the outside of the glove with your bare fingers. It will be wrong side out when removed.

CAUTION: Avoid touching your uniform or any other object with the contaminated gloves.

14. Put the contaminated gloves in an infectious waste container immediately after removal.
15. Wash your hands immediately and thoroughly after removing gloves.
16. Once the gloves have been removed, do not handle any contaminated equipment or supplies such as soiled dressings or drainage basins. Protect yourself.
17. Replace equipment if necessary.
18. Wash hands thoroughly.

Practice

Go to the workbook and use the evaluation sheet for 14:8C, Donning and Removing Sterile Gloves, to practice this procedure. When you believe you have mastered this skill, sign the sheet and give it to your instructor for further action.

Final Checkpoint Using the criteria listed on the evaluation sheet, your instructor will grade your performance.

PROCEDURE 14:8D

Changing a Sterile Dressing

Equipment and Supplies

Sterile tray with basin, solution, gauze sponges and pads (or a prepared sterile dressing package); sterile gloves; adhesive or non-allergic tape; disposable gloves; infectious waste bag

Procedure

1. Check doctor's written orders or obtain orders from immediate supervisor.

NOTE: Dressings should *not* be changed without orders.

NOTE: The policy of your agency will determine how you obtain orders for procedures.

2. Assemble equipment. Check autoclave indicator and date on all equipment. If more than 30 days have elapsed, use another package with a more recent date. Put the unsterile package aside for resterilization.
3. Wash hands thoroughly.
4. Prepare a sterile tray as previously taught in Procedure 14:8B or obtain a commercially prepared sterile dressing package.

NOTE: Prepared packages are used in some agencies.

 **CAUTION:** Never let the tray out of your sight once it has been prepared.

5. Take all necessary equipment to the patient area. Place it where it will be convenient for use yet free from possible contamination by other equipment.
6. Introduce yourself. Identify the patient. Explain the procedure. Close the door and/or windows to avoid drafts and flow of organisms into the room.

7. Screen the unit or draw curtains to provide privacy for the patient. If the patient is in a bed, elevate the bed to a comfortable working height and lower the siderail. Expose the body area needing the dressing change. Use sheets or drapes as necessary to prevent unnecessary exposure of the patient.

8. Fold down a 2- to 3-inch cuff on the top of the infectious waste bag. Position it in a convenient location. Tear off the tape you will need later to secure the clean dressing. Place it in an area where it will be available for easy access.

9. Put on disposable, nonsterile gloves.  Gently but firmly remove the tape from the soiled dressing. Discard it in the infectious waste bag. Hold the skin taut and then lift the dressing carefully, taking care not to pull on any surgical drains. Note the type, color, and amount of drainage on the dressing. Discard dressing in the infectious waste bag.

NOTE: Surgical drains are placed in some surgical incisions to aid in the removal of secretions. Care must be taken to avoid moving the drains when the dressing is removed.

10. Check the incision site. Observe the type and amount of remaining drainage, color of drainage, and degree of healing.

 **CAUTION:** Report any unusual observations immediately to your supervisor. Examples are bright red blood, pus, swelling, or abnormal discharges at the wound site or patient complaints of pain or dizziness.

11. Remove disposable gloves and place in infectious waste bag. Immediately wash your hands.

 **CAUTION:** Nonsterile disposable gloves should be worn while removing dressings to avoid contamination of the hands or skin by blood or body discharge.

PROCEDURE 14:8D

12. Fanfold the top cover back to uncover the sterile field.

CAUTION: Handle only the contaminated (outside) side of the towel. The side in contact with the tray's contents is the sterile side.

NOTE: If a prepared package is used, open it at this time.

13. Don sterile gloves as previously taught in Procedure 14:8C.
14. Using thumb and forefinger, pick up a gauze sponge from the basin. Squeeze it slightly to remove any excess solution. Warn the patient that the solution may be cool.
15. Cleanse the wound. Use a circular motion (figure 14-42).

NOTE: Begin near the center of the wound and move outward or away from the wound. Make an ever-widening circle. Discard the wet gauze sponge after use. Never go back over the same area with the same gauze sponge. Repeat this procedure until the area is clean, using a new gauze sponge each time.

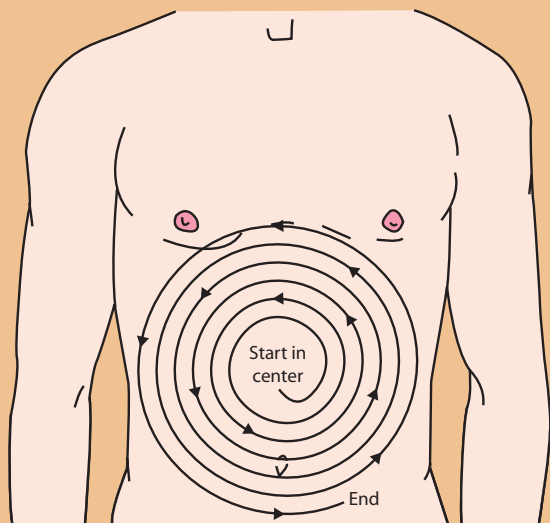

FIGURE 14-42 Use a circular motion to clean the wound, starting at the center of the wound and moving in an outward direction.

16. Do not cleanse directly over the wound unless there is a great deal of drainage or it is specifically ordered by the physician. If this is to be done, use sterile gauze and wipe with a single stroke from the top to the bottom. Discard the soiled gauze. Repeat as necessary, using a new sterile gauze sponge each time.

17. The wound is now ready for clean dressings. Lift the sterile dressings from the tray and place them lightly on the wound. Make sure they are centered over the wound.

NOTE: The inner dressing is usually made up of 4-by-4-inch gauze sponges.

18. Apply outer dressings until the wound is sufficiently protected.

NOTE: Heavier dressings such as abdominal pads are usually used.

NOTE: The number and size of dressings needed to dress the wound will depend on the amount of drainage and the size of the wound.

19. Remove the sterile gloves as previously taught. Discard them in the infectious waste bag. Immediately wash your hands.

20. Place the precut tape over the dressing at the proper angle. Check to make sure that the dressing is secure and the ends are closed.

NOTE: Tape should be applied so it runs opposite from body action or movement (figure 14-43). It should be the correct width for the dressing. It should be long enough to support the dressing, but it should not be too long because it will irritate the patient's skin.

21. Check to be sure the patient is comfortable and that safety precautions have been observed before leaving the area.

22. Put on disposable, nonsterile gloves. Clean and replace all equipment used.

PROCEDURE 14:8D



FIGURE 14-43 Tape should be applied so that it runs opposite to body action or movement.

Tie or tape the infectious waste bag securely. Dispose of it according to agency policy.

-  **CAUTION:** Disposable, nonsterile gloves should be worn to provide a protective barrier while cleaning equipment or supplies that may be contaminated by blood or body fluids.
- 23. Remove disposable gloves. Wash hands thoroughly. Protect yourself from possible contamination.
- 24. Record the following information on the patient's chart or agency form: date, time, dressing change, amount and type

of drainage, and any other pertinent information, or tell this information to your immediate supervisor.

Example: 1/8/—, 9:00 A.M. Dressing changed on right abdominal area. Small amount of thick, light-yellow discharge noted on dressings. No swelling or inflammation apparent at incision site. Sterile dressing applied. Your signature and title.

NOTE: Report any unusual observations immediately.

Practice

Go to the workbook and use the evaluation sheet for 14:8D, Changing a Sterile Dressing, to practice this procedure. When you believe you have mastered this skill, sign the sheet and give it to your instructor for further action.

-  **Final Checkpoint** Using the criteria listed on the evaluation sheet, your instructor will grade your performance.

14:9 INFORMATION

Maintaining Transmission-Based Isolation Precautions

INTRODUCTION

 In health occupations, you will deal with many different diseases/disorders. Some diseases are communicable and require isolation. A **communicable disease** is caused by a pathogenic organism that can be easily transmitted to others. An **epidemic** occurs when the communicable disease spreads rapidly from person to person and affects a large number of peo-

ple at the same time. A **pandemic** exists when the outbreak of disease occurs over a wide geographic area and affects a high proportion of the population. Because individuals can travel readily throughout the world, a major concern is that worldwide pandemics will become more and more frequent.

 **Transmission-based isolation precautions** are a method or technique of caring for patients who have communicable diseases. Examples of communicable diseases are tuberculosis, wound infections, and pertussis (whooping cough). Standard precautions, discussed in Information section 14:4, do not eliminate the need for specific transmission-based isolation

precautions. Standard precautions are used on all patients. Transmission-based isolation techniques are used to provide extra protection against specific diseases or pathogens to prevent their spread.

Communicable diseases are spread in many ways. Some examples include direct contact with the patient; contact with dirty linen, equipment, and/or supplies; and contact with blood, body fluids, secretions, and excretions such as urine, feces, droplets (from sneezing, coughing, or spitting), and discharges from wounds. Transmission-based isolation precautions are used to limit contact with pathogenic organisms. These techniques help prevent the spread of the disease to other people and protect patients, their families, and health care providers.

The type of transmission-based isolation used depends on the causative organism of the disease, the way the organism is transmitted, and whether the pathogen is antibiotic resistant (not affected by antibiotics). Personal protective equipment (PPE) is used to provide protection from the pathogen. Some transmission-based isolation precautions require the use of gowns, gloves, face shields, and masks (figure 14-44), while others only require the use of a mask.



FIGURE 14-44 Some transmission-based isolation precautions require the use of gowns, gloves, and a mask, while others only require the use of a mask.

Two terms are extensively used in transmission-based isolation: contaminated and clean. These words refer to the presence of organisms on objects.

◆ **Contaminated**, or dirty, means that objects contain disease-producing organisms. These objects must not be touched, unless the health worker is protected by gloves, gown, and other required items.

NOTE: The outside and waist ties of the gown, protective gloves, and mask are considered contaminated.

◆ **Clean** means that objects or parts of objects do *not* contain disease-producing organisms and therefore have minimal chance of spreading the disease. Every effort must be made to prevent contamination of these objects or parts of objects.

NOTE: The insides of the gloves and gown are clean, as are the neckband, its ties, and the mask ties.

The Centers for Disease Control and Prevention (CDC) in conjunction with the National Center for Infectious Diseases (NCID) and the Hospital Infection Control Practices Advisory Committee (HICPAC) has recommended four main classifications of precautions that must be followed: standard, airborne, droplet, and contact. Health care facilities are provided with a list of infections/conditions that shows the type and duration of precautions needed for each specific disease. In this way, facilities can follow the guidelines to determine the type of transmission-based isolation that should be used along with the specific precautions that must be followed.

STANDARD PRECAUTIONS

Standard precautions (discussed in Information section 14:4) are used on all patients. In addition, a patient must be placed in a private room if the patient contaminates the environment or does not (or cannot be expected to) assist in maintaining appropriate hygiene. Every health care worker must be well informed about standard precautions and follow the recommendations for the use of gloves, gowns, and face masks when conditions indicate their use.

AIRBORNE PRECAUTIONS

Airborne precautions (figure 14-45) are used for patients known or suspected to be infected with pathogens transmitted by airborne droplet nuclei. These are small particles of evaporated droplets that contain microorganisms and remain suspended in the air or on dust particles. Examples of diseases requiring these isolation precautions are rubella (measles), varicella (chicken pox), tuberculosis, and shingles or herpes zoster (varicella zoster). Standard precautions are used at all times. In addition, the following precautions must be taken:

- ◆ The patient must be placed in a private room, and the door should be kept closed.
- ◆ Air in the room must be discharged to outdoor air or filtered before being circulated to other areas.
- ◆ Each person who enters the room must wear respiratory protection in the form of an N95, P100 or more powerful filtering mask such as

a high-efficiency particulate air (HEPA) mask (figures 14-46A, B). These masks contain special filters to prevent the entrance of the small airborne pathogens. The masks must be fit tested to make sure they create a tight seal each time they are worn by a health care provider. Men with facial hair cannot wear a standard filtering mask because a beard prevents an airtight seal. Men with facial hair can use a special HEPA-filtered hood.

- ◆ People susceptible to measles or chicken pox should not enter the room.
- ◆ If at all possible, the patient should not be moved from the room. If transport is essential, however, the patient must wear a surgical mask during transport to minimize the release of droplets into the air.

DROPLET PRECAUTIONS

Droplet precautions (figure 14-47) must be followed for a patient known or suspected to be infected with pathogens transmitted by large-particle droplets expelled during coughing, sneez-

AIRBORNE PRECAUTIONS

In Addition to Standard Precautions

Visitors - Report to Nurses' Station Before Entering Room









BEFORE CARE	DURING CARE	AFTER CARE
1. Private room and closed door with monitored negative air pressure, frequent air exchanges, and high-efficiency filtration. 	1. Limit transport of patient/resident to essential purposes only. Patient/resident must wear mask appropriate for disease. 	1. Bag linen to prevent contamination of self, environment, or outside of bag. 
2. Wash hands. 	2. Limit use of noncritical care equipment to a single patient/resident. 	2. Discard infectious trash to prevent contamination of self, environment, or outside of bag. 
3. Wear respiratory protection appropriate for disease. 		3. Wash hands. 

FIGURE 14-45 Airborne precautions. (Courtesy of Brevis Corporation)



FIGURE 14-46A The N95 respirator mask.
(Courtesy of 3M Company, St. Paul, MN)



FIGURE 14-46B The P100 respirator mask.
(Courtesy of 3M Company, St. Paul, MN)

ing, talking, or laughing. Examples of diseases requiring these isolation precautions include *Haemophilus influenzae* meningitis and pneumonia; *Neisseria meningitis* and pneumonia; multidrug-resistant *Streptococcus meningitis*,

pneumonia, sinusitis, and otitis media; diphtheria; *Mycoplasma pneumoniae*; pertussis; adenovirus; mumps; and severe viral influenza. Standard precautions are used at all times. In addition, the following precautions must be taken:

DROPLET PRECAUTIONS

In Addition to Standard Precautions

Visitors - Report to Nurses' Station Before Entering Room







BEFORE CARE	DURING CARE	AFTER CARE
<p>1. Private room. Maintain 3 feet of spacing between patient/resident and visitors.</p> 	<p>1. Limit transport of patient/resident to essential purposes only. Patient/resident must wear mask appropriate for disease.</p> 	<p>1. Bag linen to prevent contamination of self, environment, or outside of bag.</p> 
<p>2. Mask/face shield for staff and visitors within 3 feet of patient/resident.</p> 	<p>2. Limit use of noncritical care equipment to a single patient/resident.</p> 	<p>2. Discard infectious trash to prevent contamination of self, environment, or outside of bag.</p> 
		<p>3. Wash hands.</p> 

FIGURE 14-47 Droplet precautions. (Courtesy of Brevis Corporation)

- ◆ The patient should be placed in a private room. If a private room is not available and the patient cannot be placed in a room with a patient who has the same infection, a distance of at least 3 feet should separate the infected patient and other patients or visitors.
- ◆ Masks must be worn when working within 3 feet of the patient, and the use of masks anywhere in the room is strongly recommended
- ◆ If transport or movement of the patient is essential, the patient must wear a surgical mask.

CONTACT PRECAUTIONS

Contact precautions (figure 14-48) must be followed for any patients known or suspected to be infected with *epidemiologically* (capable of spreading rapidly from person to person, an epidemic) microorganisms that can be transmitted by either direct or indirect contact. Examples of diseases requiring these precautions include any gastrointestinal, respiratory, skin, or wound infections caused by multidrug-resistant organisms; diapered or incontinent patients with

enterohemorrhagic *E. coli*, *Shigella*, hepatitis A, or rotavirus; viral or hemorrhagic conjunctivitis or fevers; and any skin infections that are highly contagious or that may occur on dry skin, such as diphtheria, herpes simplex virus, impetigo, pediculosis (head or body lice), scabies, and staphylococcal infections. Standard precautions are used at all times. In addition, the following precautions must be taken:

- ◆ The patient should be placed in a private room or, if a private room is not available, in a room with a patient who has an active infection caused by the same organism.
- ◆ Gloves must be worn when entering the room.
- ◆ Gloves must be changed after having contact with any material that may contain high concentrations of the microorganism, such as wound drainage or fecal material.
- ◆ Gloves must be removed before leaving the room, and the hands must be washed with an antimicrobial agent.
- ◆ A gown must be worn in the room if there is any chance of contact with the patient, environmental surfaces, or items in the room. The

CONTACT PRECAUTIONS

In Addition to Standard Precautions

Visitors - Report to Nurses' Station Before Entering Room









BEFORE CARE	DURING CARE	AFTER CARE
1. Private room. 	1. Limit transport of patient/resident to essential purposes only. Patient/resident must wear mask appropriate for disease. 	1. Bag linen to prevent contamination of self, environment, or outside of bag. 
2. Wash hands. 	2. Limit use of noncritical care equipment to a single patient/resident. 	2. Discard infectious trash to prevent contamination of self, environment, or outside of bag. 
3. Wear gown if soiling is likely. 		3. Wash hands. 
4. Wear gloves when entering room. Change after contact with infective material. 		

FIGURE 14-48 Contact precautions. (Courtesy of Brevis Corporation)

gown must be removed before leaving the room and care must be taken to ensure that clothing is not contaminated after gown removal.

- ◆ Movement and transport of the patient from the room should be for essential purposes only.
- ◆ The room and items in it must receive daily cleaning and disinfection as needed.
- ◆ If possible, patient-care equipment (bedside commode, stethoscope, sphygmomanometer, thermometer) should be left in the room and used only for this patient. If this is not possible, all equipment must be cleaned and disinfected before being used on another patient.

PROTECTIVE OR REVERSE ISOLATION

Protective or **reverse isolation** refers to methods used to protect certain patients from organisms present in the environment. Protective isolation is used mainly for *immunocompromised* patients, or those whose body defenses are not capable of protecting them from infections and disease. Examples of patients requiring this protection are patients whose immune systems have been depressed prior to receiving transplants (such as bone marrow transplants), severely burned patients, patients receiving chemotherapy or radiation treatments for cancer, or patients whose immune systems have failed. Precautions vary depending on the patient's condition. Standard precautions are used at all times. In addition, the following precautions may be taken:

- ◆ The patient is usually placed in a room that has been cleaned and disinfected

PROCEDURE 14:9A

Donning and Removing Transmission-Based Isolation Garments



NOTE: The following procedure deals with contact transmission-based isolation precautions. For other types of

- ◆ Frequent disinfection occurs while the patient occupies the room
- ◆ Anyone entering the room must wear clean or sterile gowns, gloves, and masks
- ◆ All equipment or supplies brought into the room are clean, disinfected, and/or sterile
- ◆ Special filters may be used to purify air that enters the room
- ◆ Every effort is made to protect the patient from microorganisms that cause infection or disease

SUMMARY

Exact procedures for maintaining transmission-based isolation precautions vary from one facility to another. The procedures used depend on the type of units provided for isolation patients, and on the kind of supplies or special isolation equipment available. Most facilities convert a regular patient room into an isolation room, but some facilities use special, two-room isolation units. Most facilities use disposable supplies such as gloves, gowns, and treatment packages. Therefore, it is essential that you learn the isolation procedure followed by your agency. However, the basic principles for maintaining transmission-based isolation are the same regardless of the facility. Therefore, if you know these basic principles, you will be able to adjust to any setting.

STUDENT: Go to the workbook and complete the assignment sheet for 14:9, *Maintaining Transmission-Based Isolation Precautions*. Then return and continue with the procedures.

transmission-based isolation, follow only the steps that apply.

Equipment and Supplies

Isolation gown, surgical mask, gloves, small plastic bag, linen cart or container, infectious waste container, paper towels, sink with running water

PROCEDURE 14:9A

Procedure

1. Assemble equipment.

NOTE: In many agencies, clean isolation garments and supplies are kept available on a cart outside the isolation unit, or in the outer room of a two-room unit. A waste container should be positioned just inside the door.

2. Wash hands.
3. Remove rings and place them in your pocket or pin them to your uniform.
4. Remove your watch and place it in a small plastic bag or centered on a clean paper towel. If placed on a towel, handle only the bottom part of the towel; do not touch the top.

NOTE: The watch will be taken into the room and placed on the bedside stand for taking vital signs. Because it cannot be sterilized, it must be kept clean.

NOTE: In some agencies, a plastic-covered watch is left in the isolation room.

5. Put on the mask. Secure it under your chin. Make sure to cover your mouth and nose. Handle the mask as little as possible. Tie the mask securely behind your head and neck. Tie the top ties first and the bottom ties second (figure 14-49A).



FIGURE 14-49A Put on the mask, tying the top ties before the bottom ties.



FIGURE 14-49B After tying the mask in place, put on the gown by placing your hands inside the shoulders to ease your arms into the sleeves.

NOTE: The tie bands on the mask are considered clean. The mask is considered contaminated.

NOTE: The mask is considered to be contaminated after 30 minutes in isolation or anytime it gets wet. If you remain in isolation longer than 30 minutes, or if the mask gets wet, you must wash your hands, and remove and discard the old mask. Then wash your hands again, and put on a clean mask.

6. If uniform sleeves are long, roll them up above the elbows before putting on the gown.
7. Lift the gown by placing your hands inside the shoulders.

NOTE: The inside of the gown and the ties at the neck are considered clean.

NOTE: Most agencies use disposable gowns that are discarded after use.

8. Work your arms into the sleeves of the gown by gently twisting (figure 14-49B). Take care not to touch your face with the sleeves of the gown.
9. Place your hands *inside* the neckband, adjust until it is in position, and then tie the bands at the back of your neck (figure 14-49C).



FIGURE 14-49C Slip your fingers inside the neckband to tie the gown at the neck.

PROCEDURE 14:9A

10. Reach behind and fold the edges of the gown over so that the uniform is completely covered. Tie the waistbands (figure 14-49D). Some waistbands are long enough to wrap around your body before tying.
11. If gloves are to be worn, put them on. Make sure that the cuff of the glove comes over the top of the cuff of the gown (figure 14-49E). In this way, there are no open areas for entrance of organisms.
12. You are now ready to enter the isolation room. Double-check to be sure you have all equipment and supplies that you will need for patient care before you enter the room.
13. When patient care is complete, you will be ready to remove isolation garments. In a two-room isolation unit, go to the outer room. In a one-room unit, remove garments while you are standing close to the inside of the door. Take care to avoid touching the room's contaminated articles.
14. Untie the waist ties (figure 14-50A). Loosen the gown at the waist.



FIGURE 14-49D Overlap the back edges of the gown so your uniform is completely covered before tying the waist ties.

NOTE: The waist ties are considered contaminated.

15. If gloves are worn, remove the first glove by grasping the outside of the cuff with the opposite gloved hand. Pull the glove over the hand so that the glove is inside out (figure 14-50B). Remove the second glove by placing the bare hand inside the cuff. Pull the glove off so it is inside out. Place the disposable gloves in the infectious waste container.
16. To avoid unnecessary transmission of organisms, use paper towels to turn on the water faucet. Wash and dry your hands thoroughly. When they are dry, use a clean, dry paper towel to turn off the faucet.

CAUTION: Organisms travel rapidly through wet towels.

17. Untie the bottom ties of the mask first followed by the top ties. Holding the mask by the top ties only, drop it into the infectious waste container (figure 14-50C).

NOTE: The ties of the mask are considered clean. Do not touch any other part of the mask, because it is considered contaminated.



FIGURE 14-49E Put on gloves making sure that the cuff of the glove is over the top of the cuff on the gown.

PROCEDURE 14:9A

18. Untie the neck ties. Loosen the gown at the shoulders, handling only the inside of the gown.

NOTE: The neck ties are considered clean.

19. Slip the fingers of one hand inside the opposite cuff. Do *not* touch the outside. Pull the sleeve down over the hand (figure 14-50D).

CAUTION: The outside of the gown is considered contaminated and should not be touched.

20. Using the gown-covered hand, pull the sleeve down over the opposite hand (figure 14-50E).

21. Ease your arms and hands out of the gown. Keep the gown in front of your body and keep your hands away from the outside of the gown. Use as gentle a motion as possible.

NOTE: Excessive flapping of the gown will spread organisms.

22. With your hands inside the gown at the shoulders, bring the shoulders together and turn the gown so that it is inside out (figure 14-50F). In this manner, the outside of the contaminated gown is on the inside. Fold the gown in half and then roll it together. Place it in the infectious waste container.

NOTE: Avoid excess motion during this procedure because motion causes the spread of organisms.

23. Wash hands thoroughly. Use dry, clean paper towels to operate the faucets.

24. Touch only the inside of the plastic bag to remove your watch. Discard the bag in the waste container. If the watch is on a paper towel, handle only the “clean,” top portion (if necessary). Discard the towel in the infectious waste container.

25. Use a clean paper towel to open the door. Discard the towel in the waste container before leaving the room.

CAUTION: The inside of the door is considered contaminated.



FIGURE 14-50A Untie the waist ties of the gown before removing the gloves.



FIGURE 14-50B To remove the gloves, pull them over the hand so the glove is inside out.



FIGURE 14-50C Remove the mask and hold only the top ties to drop it in an infectious waste container.

PROCEDURE 14:9A



FIGURE 14-50D To remove the gown, slip the fingers of one hand under the cuff of the opposite arm to pull the gown down over the opposite hand.



FIGURE 14-50E Using the gown-covered hand, grasp the outside of the gown on the opposite arm and pull the gown down over the hand.

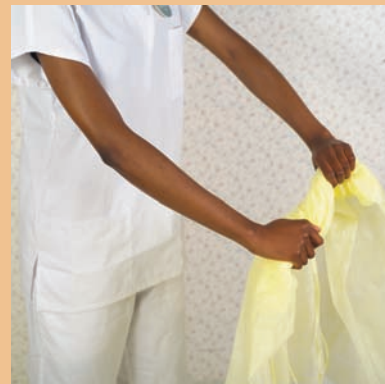



FIGURE 14-50F With your hands inside the gown at the shoulders, bring the shoulders together and turn the gown so that it is inside out, with the contaminated side on the inside.

NOTE: The waste container should be positioned just inside the door of the room.

26. After leaving the isolation room, wash hands thoroughly. This will help prevent spread of the disease. It also protects you from the illness.

 **Final Checkpoint** Using the criteria listed on the evaluation sheet, your instructor will grade your performance.

Practice

Go to the workbook and use the evaluation sheet for 14:9A, Donning and Removing Transmission-Based Isolation Garments, to practice this procedure. When you believe you have mastered this skill, sign the sheet and give it to your instructor for further action.

PROCEDURE 14:9B

Working in a Hospital Transmission-Based Isolation Unit

Equipment and Supplies

Clothes hamper, two laundry bags, two trays, dishes, cups, bowls, waste container lined with a plastic bag, infectious waste bags, bags, tape, pencil, pen, paper

Procedure

1. Assemble all equipment.

NOTE: Any equipment or supplies to be used in the isolation room must be assembled prior to entering the room.

2. Wash hands.
3. Put on appropriate isolation garments as previously instructed.

PROCEDURE 14:9B

4. Tape paper to the outside of the isolation door. This will be used to record vital signs.
5. Enter the isolation room. Take all needed equipment into the room.
6. Introduce yourself. Greet and identify patient. Provide patient care as needed.

NOTE: All care is provided in a routine manner. However, transmission-based isolation garments must be worn as ordered.

7. To record vital signs:
 - a. Take vital signs using the watch in the plastic bag. (If the watch is not in a plastic bag, hold it with the bottom part of a paper towel.) Use other equipment in the room as needed.
 - b. Open the door touching only the inside, or contaminated side.
 - c. Using a pencil, record the vital signs on the paper taped to the door. Do *not* touch the outside of the door at any time.

NOTE: The pencil remains in the room because it is contaminated.

8. To transfer food into the isolation unit:
 - a. Transfer of food requires two people; one person must stay outside the unit and one inside.
 - b. The person inside the isolation unit picks up the empty tray in the room and opens door, touching only the inside of the door.
 - c. The person outside holds the tray while the dishes are being transferred (figure 14-51).
 - d. When transferring food, the two people should handle the opposite sides of the dishes. In this manner, one person will not touch the other person.



FIGURE 14-51 To transfer food into an isolation unit, a health care worker holds the tray so the worker in isolation can transfer the food onto the tray kept inside the unit.

- e. Glasses should be held near the top by the transfer person on the outside. The transfer person on the inside should receive the glasses by holding them on the bottom.
9. To dispose of leftover food or waste:
 - a. Liquids can be poured down the sink or flushed down the toilet.
 - b. Soft foods such as mashed potatoes or cooked vegetables can be flushed down the toilet.
 - c. Hard particles of food, such as bone, should be placed in the plastic-lined trash container.
 - d. Disposable utensils or dishes should be placed in the plastic-lined trash container.
 - e. Metal utensils should be washed and kept in the isolation room to be used as needed for other meals. These

PROCEDURE 14:9B

utensils, however, are contaminated. When they are removed from the isolation room, they must be disinfected or double bagged and labeled before being sent for decontamination and reprocessing.

10. To transfer soiled linen from the unit, two people are required:
 - a. All dirty linen should be folded and rolled.
 - b. Place linen in the linen hamper.
 - c. The person outside the unit should cuff the top of a clean infectious waste laundry bag and hold it. Hands should be kept on the inside of the bag's cuff to avoid contamination.
 - d. The person in isolation should seal the isolation bag. The bag is then placed inside the outer bag, which is being held by the person outside.
 - e. Outer bag should be folded over at the top and taped by the person outside. The bag should be labeled as "BIOHAZARDOUS LINEN."
 - f. At all times, no direct contact should occur between the two people transferring linen.

NOTE: Many agencies use special isolation linen bags. Hot water dissolves the bags during the washing process. Therefore, no other personnel handle the contaminated linen after it leaves the isolation unit.

11. To transfer trash from the isolation unit, two people are required:
 - a. Any trash in the isolation room should be in plastic bags. Any trash or disposable items contaminated with blood, body fluids, secretions, or excretions should be placed in infectious waste bags.
 - b. When the bag is full, expel excess air by pushing gently on the bag.

- c. Tie a knot at the top of the bag to seal it or fold the top edge twice and tape it securely.
- d. Place this bag inside a cuffed biohazardous waste bag held by a "clean" person outside the unit (figure 14-52).
- e. The outside person then ties the outer bag securely or tapes the outer bag shut.
- f. The double-bagged trash should then be burned. Double-bagged infectious waste is autoclaved prior to incineration or disposal as infectious waste according to legal requirements.
- g. At all times, direct contact between the two people transferring trash must be avoided.

12. To transfer equipment from the isolation unit two people are required:



FIGURE 14-52 To transfer infectious waste from an isolation unit, the worker in the unit places the sealed infectious waste bag inside a second bag held by a "clean" worker outside the unit.

PROCEDURE 14:9B

- a. Thoroughly clean and disinfect all equipment in the unit.
 - b. After cleaning, place equipment in a plastic bag or special isolation bag. Label the bag with the contents and the word “ISOLATION.”
 - c. After folding the bag down twice at the top, tape the bag shut.
 - d. A second person outside the isolation room should hold a second, cuffed infectious waste bag.
 - e. The person in isolation places the sealed, contaminated bag inside the bag being held outside the unit. The person in isolation should have no direct contact with the clean bag.
 - f. The person outside the unit turns down the top of the infectious waste bag twice and securely tapes the bag. The outside person then labels the bag with the contents, for example, “ISOLATION DISHES.”
 - g. The double-bagged material is then sent to Central Supply or another designated area for sterilization and/or decontamination.
13. The transmission-based isolation unit must be kept clean and neat at all times. Equipment no longer needed should be transferred out of the unit using the appropriate isolation technique.
14. Before leaving an isolation room, ask the patient whether a urinal or bedpan is needed. This will save time and energy by reducing the need to return to provide additional patient care shortly after leaving. Also, prior to leaving, check all safety and comfort points to make sure patient care is complete.
 15. Remove isolation garments as previously instructed in Procedure 14:9A.
 16. Wash hands thoroughly.

Practice

Go to the workbook and use the evaluation sheet for 14:9B, Working in a Hospital Transmission-Based Isolation Unit, to practice this procedure. When you believe you have mastered this skill, sign the sheet and give it to your instructor for further action.



Final Checkpoint Using the criteria listed on the evaluation sheet, your instructor will grade your performance.

CHAPTER 14 SUMMARY

Understanding the basic principles of infection control is essential for any health care worker in any health care field. Disease is caused by a wide variety of pathogens, or germs. An understanding of the types of pathogens, methods of transmission, and the chain of infection allows health care workers to take precautions to prevent the spread of disease.

Bioterrorism is the use of microorganisms as weapons to infect humans, animals, or plants. The CDC has identified and classified agents

that could be used for bioterrorism. In today's world, it is likely that an attack will occur. Every health care worker must constantly be alert to the threat of bioterrorism. Careful preparation of a comprehensive plan against bioterrorism and thorough training of all individuals can limit the effect of the attack and save the lives of many people.

Asepsis is defined as “the absence of disease-producing microorganisms, or pathogens.” Various levels of aseptic control are possible. Antiseptics refers to methods that prevent or inhibit the growth of pathogenic organisms. Proper handwashing and using an ultrasonic unit to

TODAY'S RESEARCH: TOMORROW'S HEALTH CARE

Super water that kills germs?

Treating chronic wounds is a multibillion-dollar market worldwide. Any health product catalog advertises hundreds of antiseptics and disinfectants designed to kill germs. However, many of these products irritate the skin, and only a few can be used on open infected sores.

Now scientists have created a superoxygenated water, Microcyn, that appears to kill bacteria, viruses, fungi, mold, and spores. Microcyn is water mixed with salt that has been charged with an electric current to create superoxidized water. The highly oxidized water contains hydrogen ions that have been split. The ions surround and rupture the cell wall of a single-cell organism, such as a bacterium or virus, and cause the organism to lose its cytoplasm, effectively killing the cell. Multicellular organisms, such as humans, are not affected by the ions because their cells are packed closely together, forming an effective wall to prevent the superoxygenated water from surrounding the cells. Early tests show that chronic diabetic ulcers and burns heal quickly when this solution is used in place of other antiseptics.

In the United States, approximately 18.2 million people, or 6.3 percent of the population, have diabetes. As the disease progresses, many of these individuals experience development of chronic ulcers that do not heal. Statistics show that more than 60 percent of non-traumatic lower leg amputations occur in people with diabetes. Many amputations could be avoided if chronic ulcers could be healed. In addition, think of the many other uses for this superwater. It could be used as an effective handwashing agent. It could be used as a spray mist to disinfect a room. It might even prove to be an agent that can be used to stop a flu epidemic or a biologic terrorist attack. If this superwater can destroy many of the germs that cause disease, it will change health care.

clean instruments and supplies are examples. Disinfection is a process that destroys or kills pathogenic organisms, but is not always effective against spores and viruses. Chemical disinfectants are used for this purpose. Sterilization is a process that destroys all microorganisms, including spores and viruses. The use of an autoclave is an example. Instruments and equipment are properly prepared, and then processed in the autoclave to achieve sterilization.

Following the standard precautions established by the CDC helps prevent the spread of pathogens by way of blood, body fluids, secretions, and excretions. The standard precautions provide guidelines for handwashing; wearing gloves; using gowns, masks, and protective eyewear when splashing is likely; proper handling and disposal of contaminated sharp objects; proper disposal of contaminated waste; and proper methods to wipe up spills of blood, body fluids, secretions, and excretions. Every health care worker must be familiar with and follow

the recommended standard precautions while working with all patients.

Sterile techniques are used in specific procedures, such as changing dressings. Health care workers must learn and follow sterile techniques when they are required to perform these procedures.

Transmission-based isolation precautions are used for patients who have communicable diseases, or diseases that are easily transmitted from one person to another. An awareness of the major types of transmission-based isolation presented in this unit will help the health care worker prevent the transmission of communicable diseases.

Infection control must be followed when performing any and every health care procedure. By learning and following the principles discussed in this unit, health care workers will protect themselves, patients, and others from disease.

INTERNET SEARCHES

Use the suggested search engines in Chapter 12:4 of this textbook to search the Internet for additional information on the following topics:

1. *Organizations regulating infection control*: find the organization sites for the Occupational Safety and Health Administration (OSHA), Centers for Disease Control and Prevention (CDC), National Center for Infectious Diseases (NCID), and the Hospital Infection Control Practices Advisory Committee (HICPAC) to obtain information on regulations governing infection control
2. *Microbiology*: search for specific information on bacteria (can also search for specific types such as *Escherichia coli*), protozoa, fungi, rickettsiae, and viruses
3. *Diseases*: obtain information on the method of transmission, signs and symptoms, treatment, and complications for diseases such as hepatitis B, hepatitis C, acquired immune deficiency syndrome, and specific diseases listed by the discussion on microorganisms in this unit
4. *Infections*: research endogenous infections, exogenous infections, nosocomial infections, and opportunistic infections
5. *Bioterrorism*: find information on pathogens that can be used as weapons, how they are spread, methods for prevention and/or treatment of diseases caused by the pathogens, and bioterrorism preparedness plans developed as a result of the Bioterrorism Act of 2002
6. *Foreign trip*: plan a trip to an exotic foreign country; research the Internet to determine specific health precautions that must be taken during your stay, and determine which immunizations you will need before the trip
7. *Infection control*: locate and read the Blood-borne Pathogen Standards, Needlestick Safety

and Prevention Act, Standard Precautions, and Transmission-Based Isolation Precautions (airborne precautions, droplet precautions, and contact precautions)

8. *Medical supply companies*: search for names of specific medical supply companies to research products available such as autoclaves, chemical disinfectants, and spill clean-up kits

REVIEW QUESTIONS

1. List the classifications of bacteria by shape and give two (2) examples of diseases caused by each class.
2. Draw the chain of infection and identify three (3) ways to break each section of the chain.
3. Differentiate between antisepsis, disinfection, and sterilization.
4. Develop a plan showing at least five (5) ways you can protect yourself and your family from a bioterrorism attack.
5. List eight (8) times the hands must be washed.
6. Name the different types of personal protective equipment (PPE) and state when each type must be worn to meet the requirements of standard precautions.
7. What level of infection control is achieved by an ultrasonic cleaner? chemicals? an autoclave?
8. Name three (3) methods that can be used to place sterile items on a sterile field. Identify the types of items that can be transferred by each method.
9. List the three (3) types of transmission-based isolation precautions and the basic principles that must be followed for each type.